



US 20180047462A1

(19) **United States**

(12) **Patent Application Publication**
McGuire

(10) **Pub. No.: US 2018/0047462 A1**

(43) **Pub. Date: Feb. 15, 2018**

(54) **ENCAPSULATING MAGNETIC FIELDS FOR PLASMA CONFINEMENT**

089, filed on Apr. 3, 2013, provisional application No. 61/808,101, filed on Apr. 3, 2013, provisional application No. 61/808,154, filed on Apr. 3, 2013.

(71) Applicant: **Lockheed Martin Corporation**,
Bethesda, MD (US)

Publication Classification

(72) Inventor: **Thomas John McGuire**, Palmdale, CA (US)

(51) **Int. Cl.**
G21B 1/05 (2006.01)

(21) Appl. No.: **14/242,971**

(52) **U.S. Cl.**
CPC **G21B 1/057** (2013.01)

(22) Filed: **Apr. 2, 2014**

(57) **ABSTRACT**

Related U.S. Application Data

(60) Provisional application No. 61/808,131, filed on Apr. 3, 2013, provisional application No. 61/808,136, filed on Apr. 3, 2013, provisional application No. 61/808,122, filed on Apr. 3, 2013, provisional application No. 61/807,932, filed on Apr. 3, 2013, provisional application No. 61/808,110, filed on Apr. 3, 2013, provisional application No. 61/808,066, filed on Apr. 3, 2013, provisional application No. 61/808,093, filed on Apr. 3, 2013, provisional application No. 61/808,

In one embodiment, a fusion reactor includes an enclosure, an open-field magnetic system comprising one or more internal magnetic coils suspended within the enclosure, and one or more encapsulating magnetic coils coaxial with the one or more internal magnetic coils of the open-field magnetic system. The one or more encapsulating magnetic coils form a magnetosphere around the open-field magnetic system. The open-field magnetic system and the one or more encapsulating magnetic coils, when supplied with electrical currents, form magnetic fields for confining plasma within the enclosure,

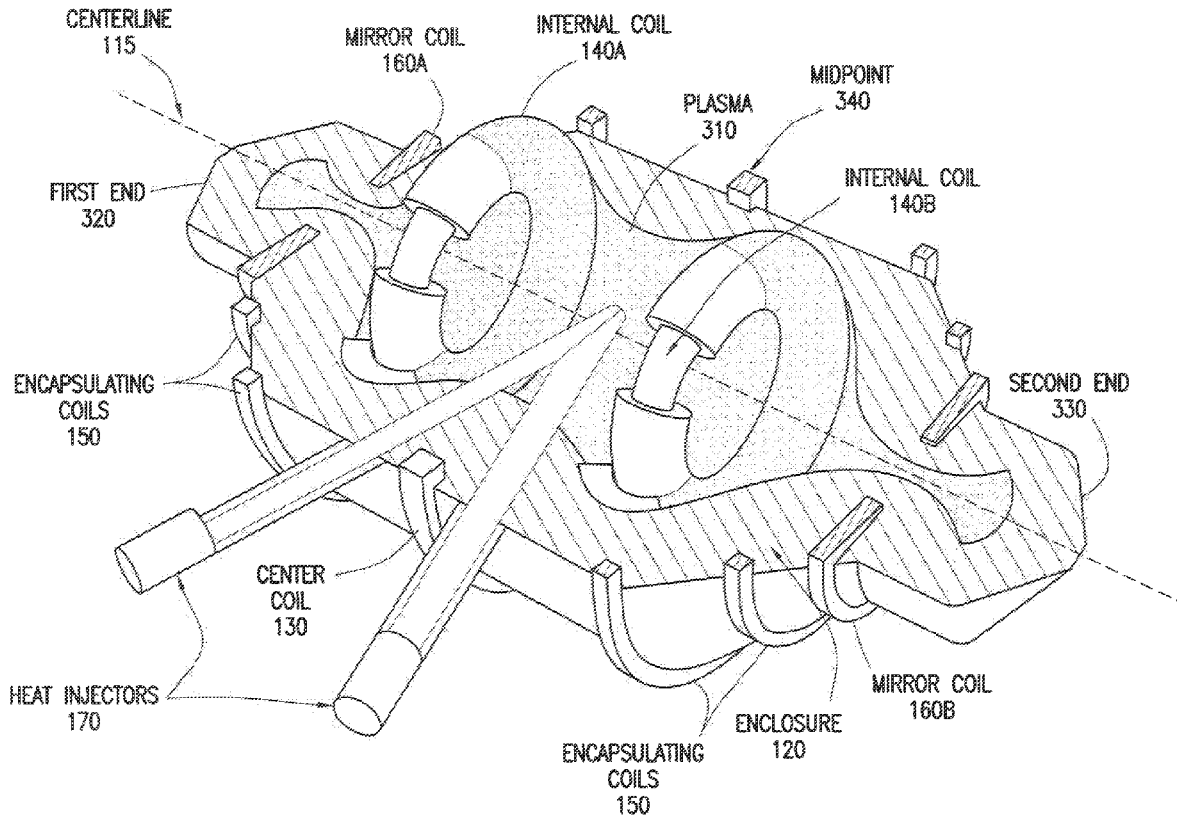

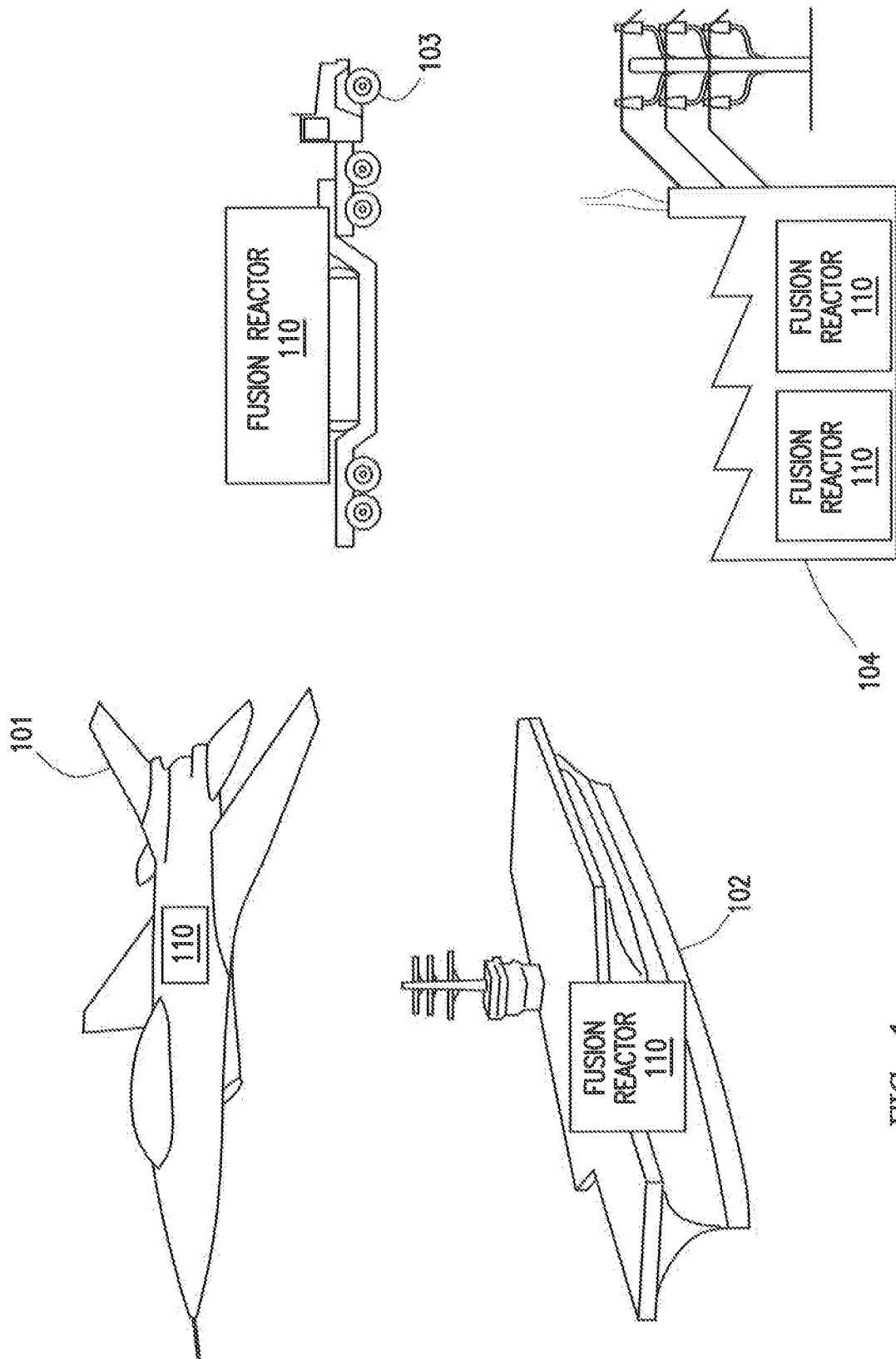

FIG. 1

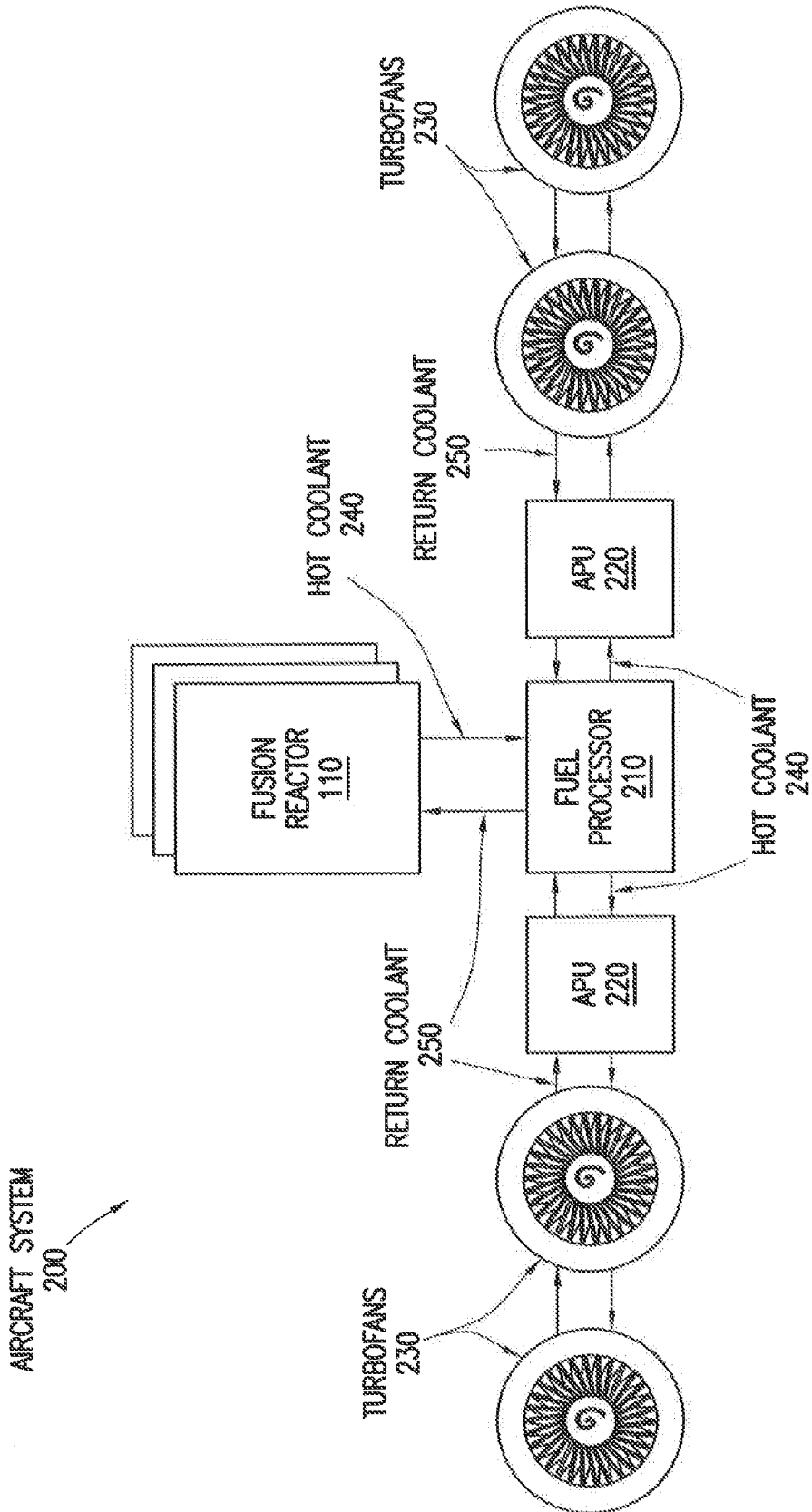

FIG. 2

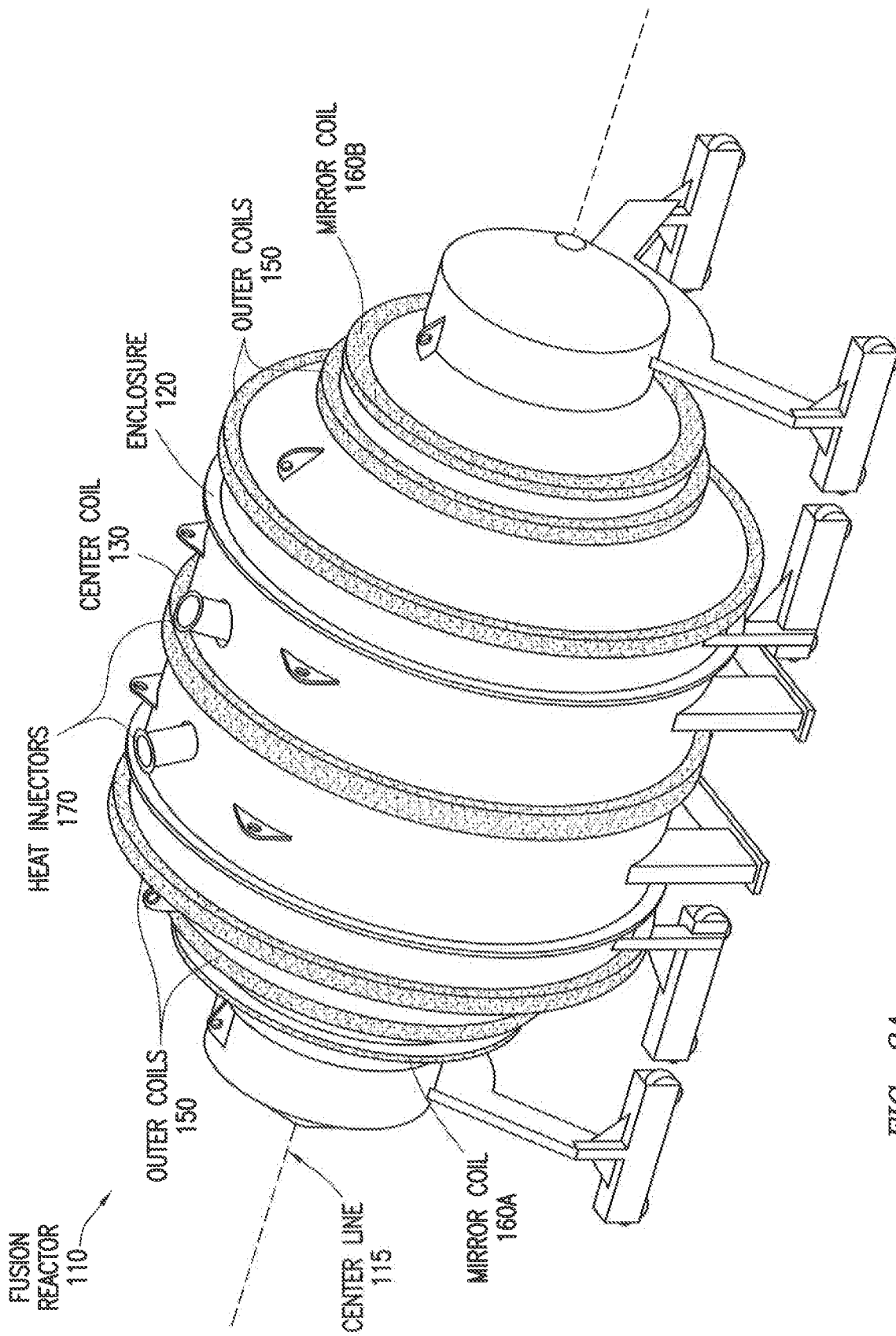

FIG. 3A

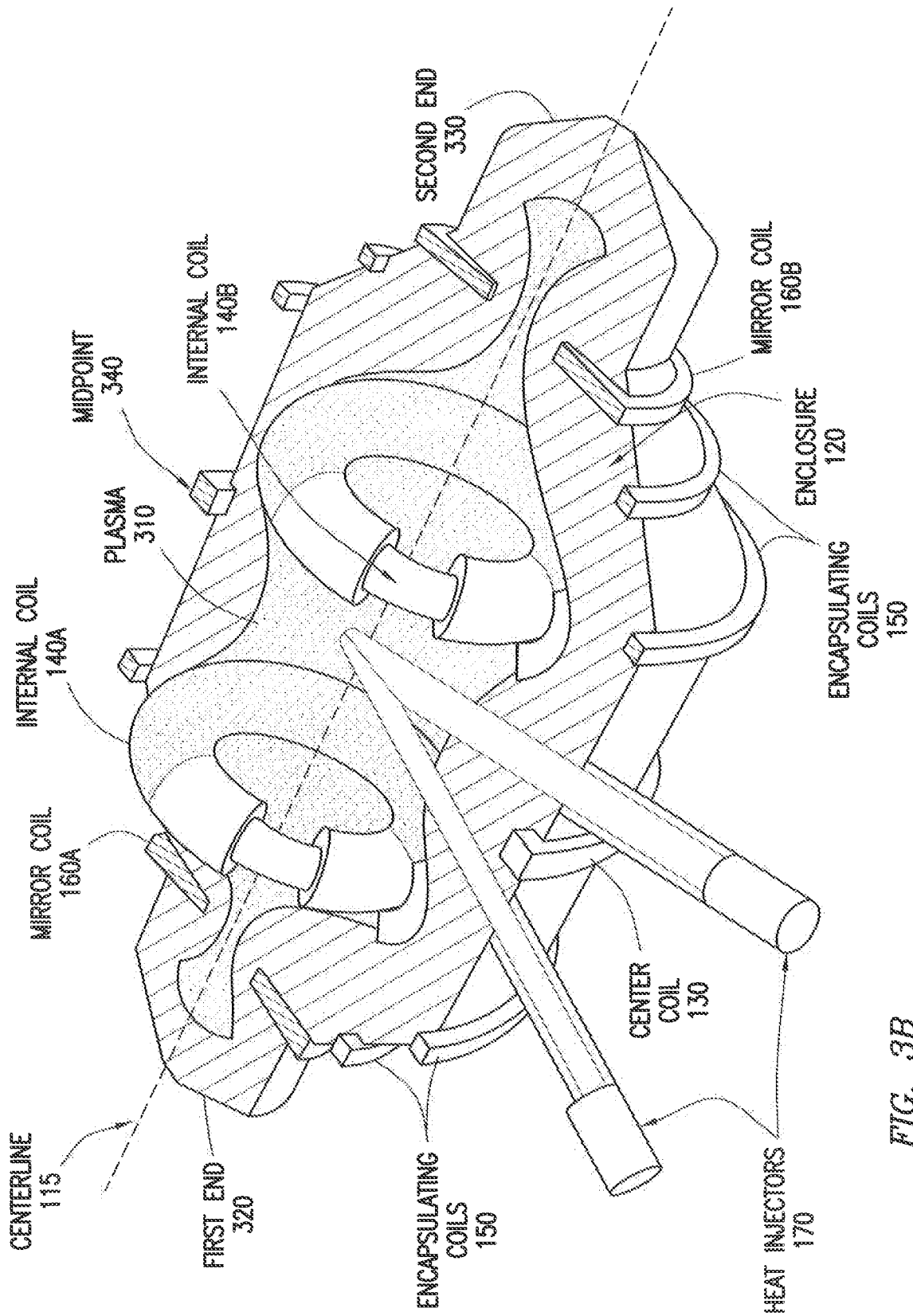

FIG. 3B

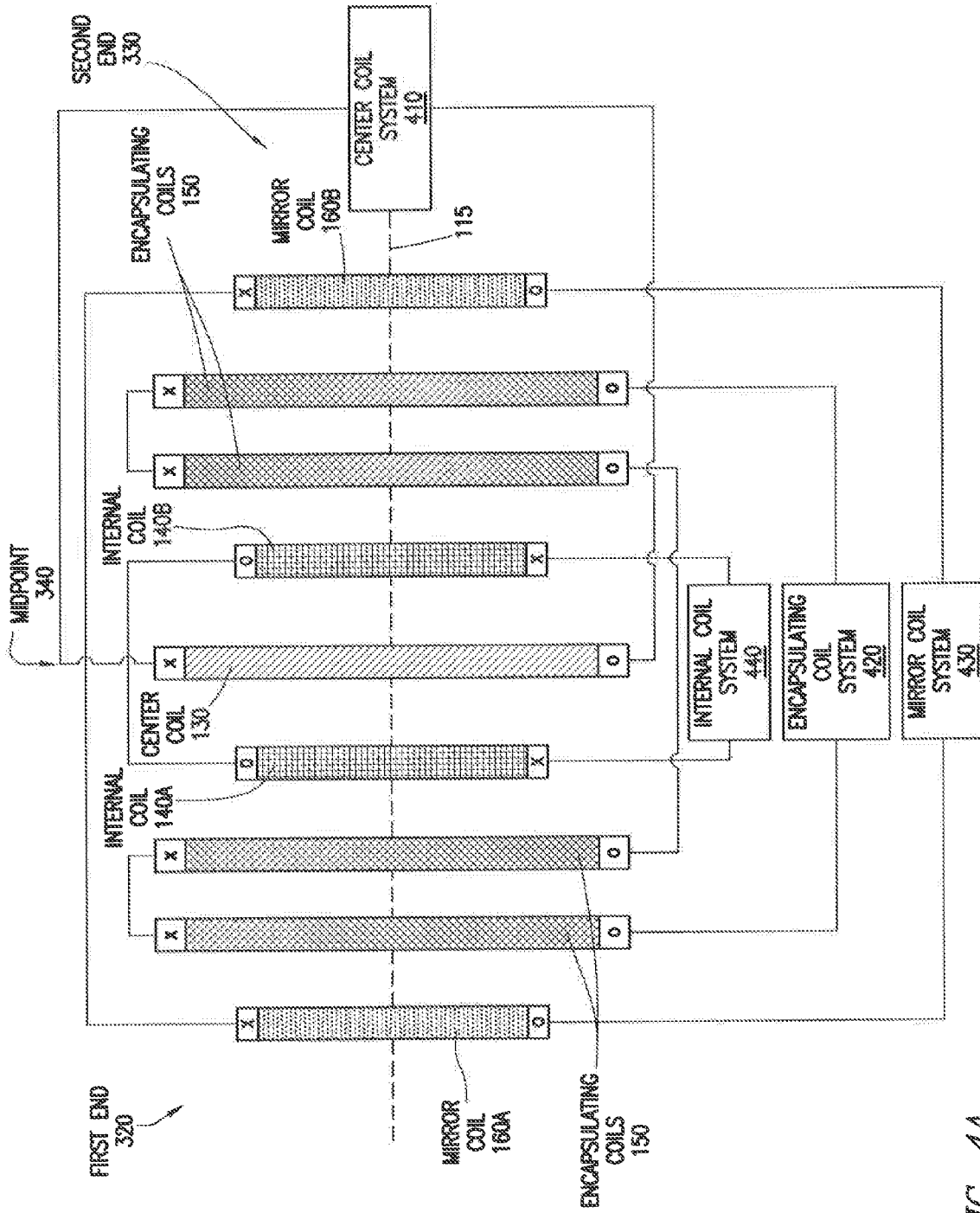

FIG. 4A

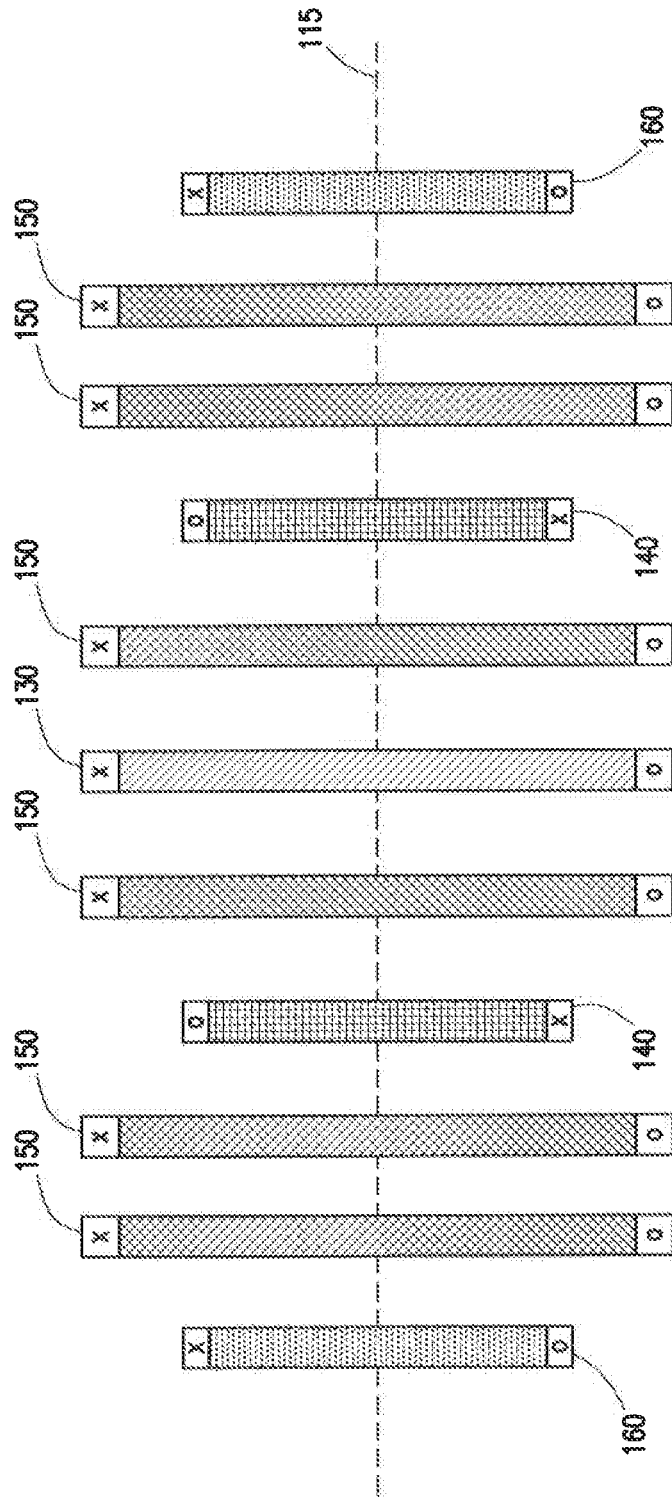

FIG. 4B

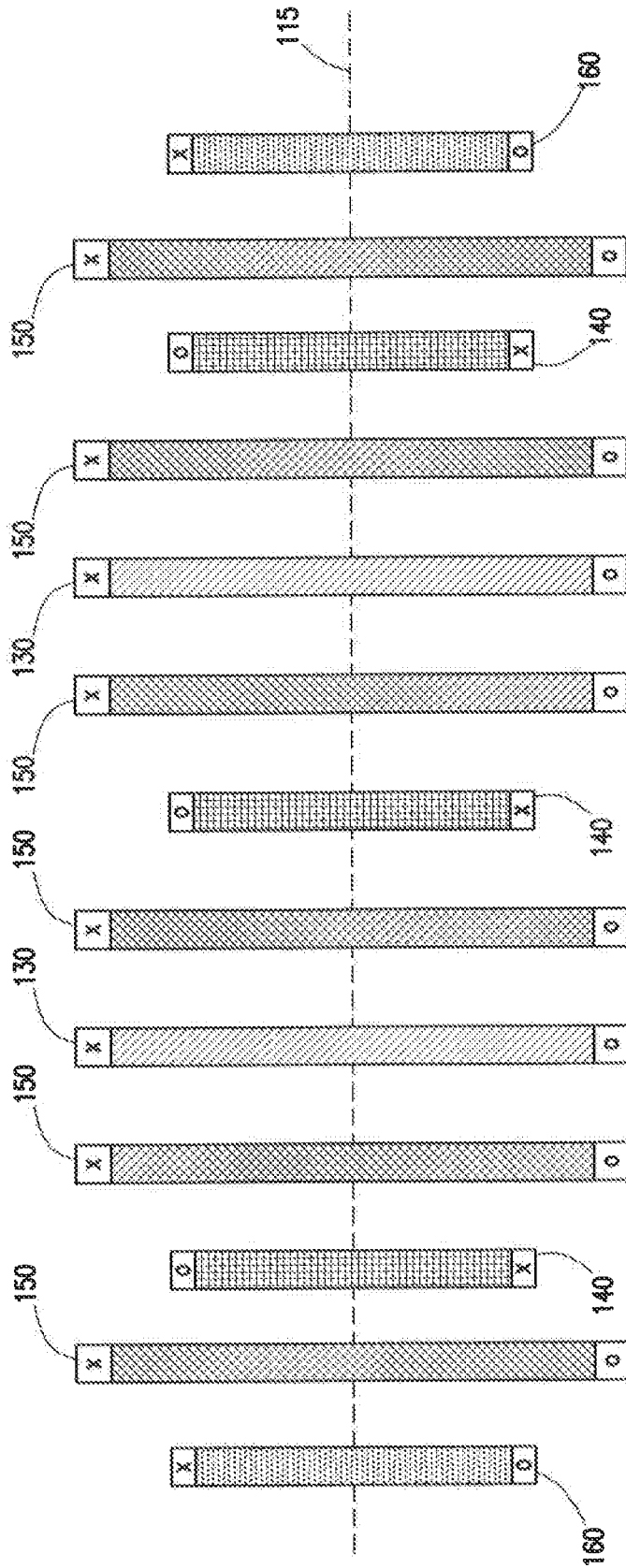

FIG. 4C

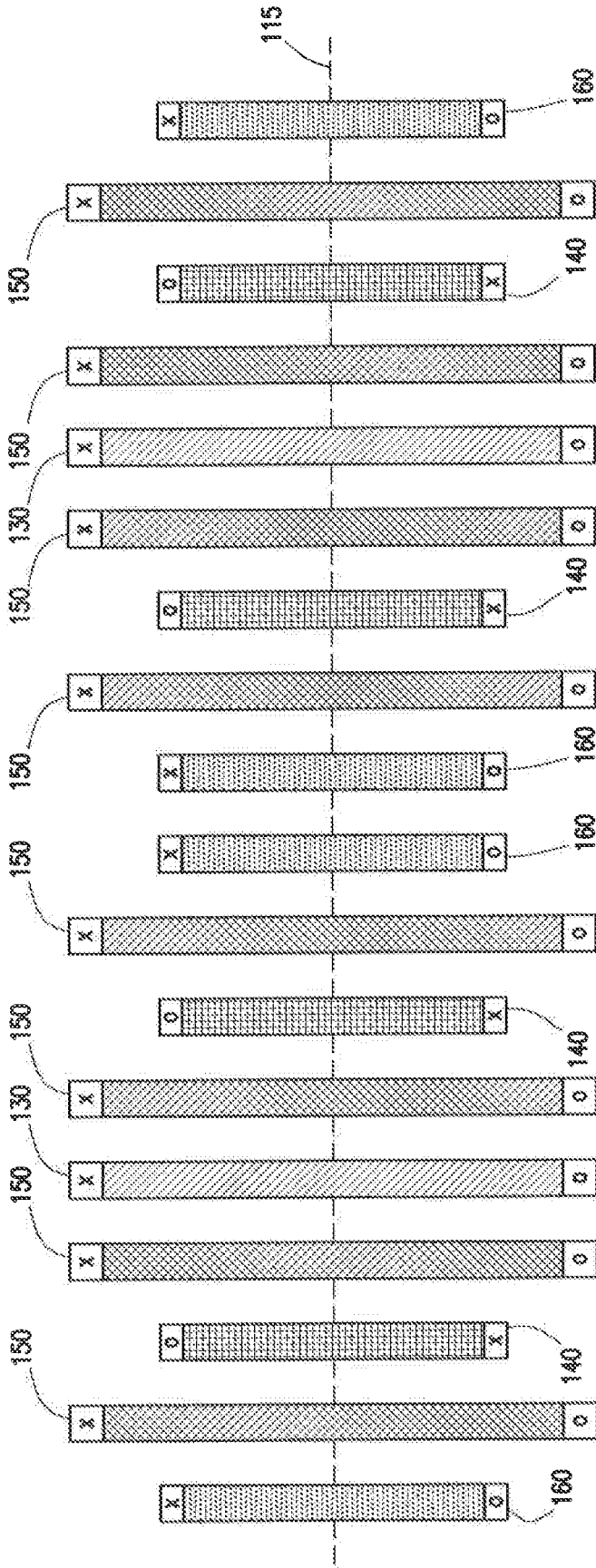

FIG. 4D

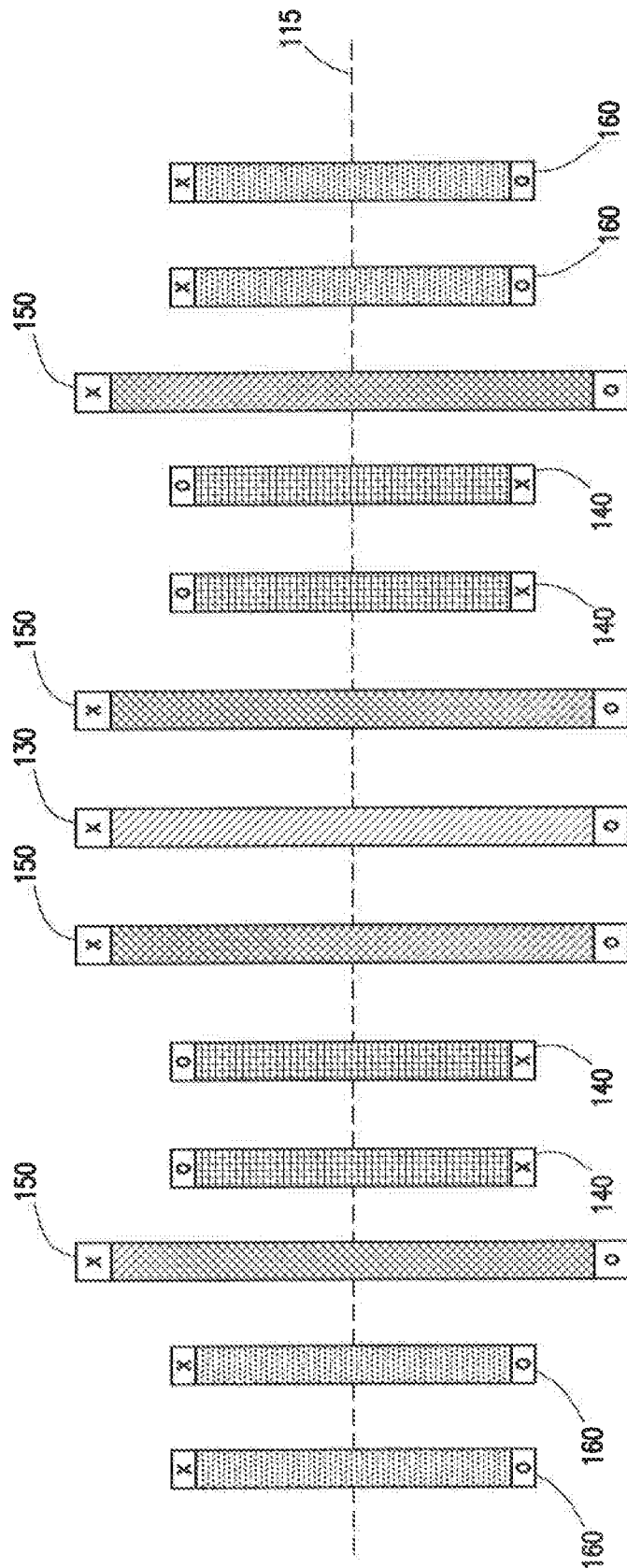

FIG. 4E

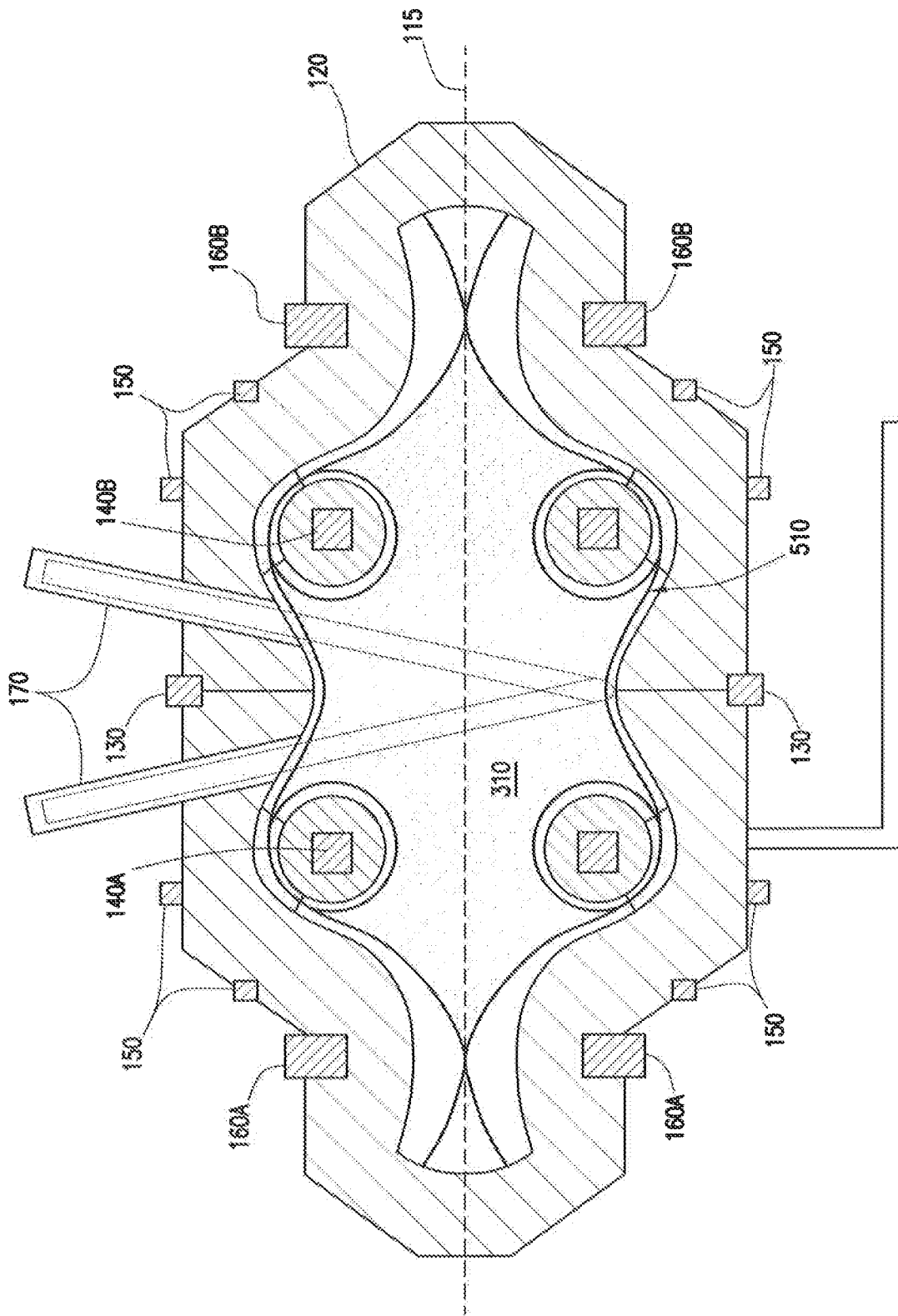

FIG. 5

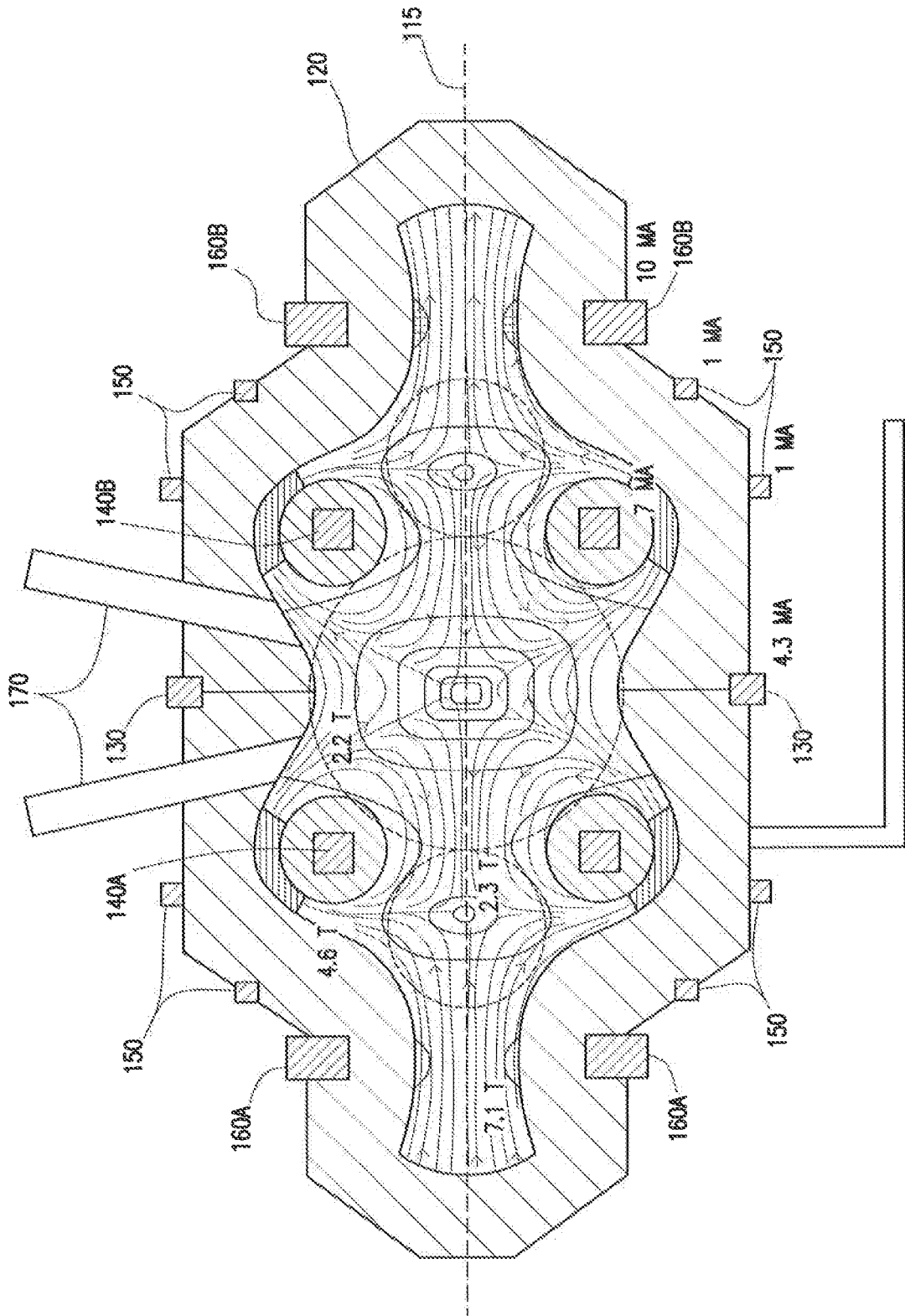

FIG. 6

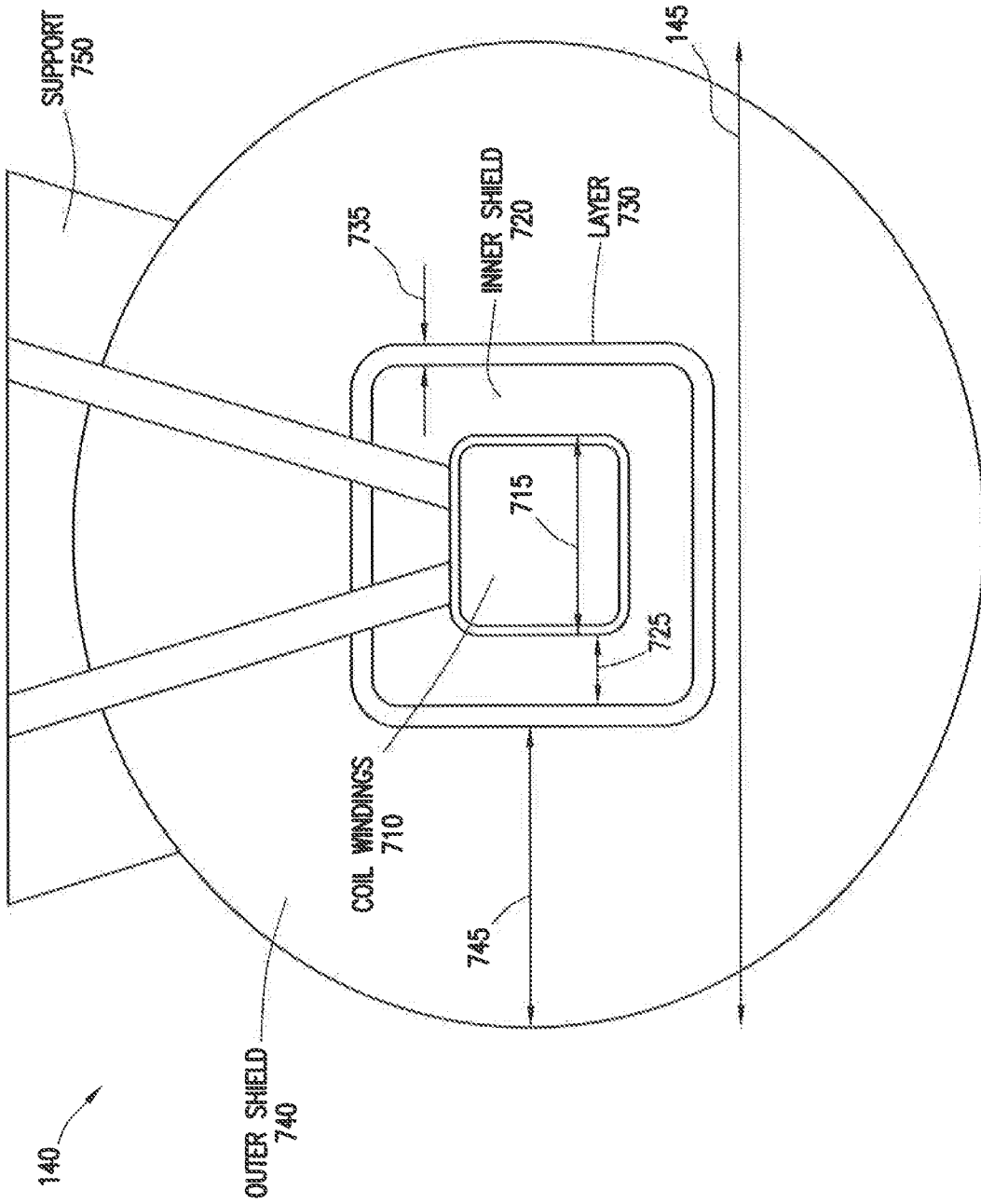

FIG. 7

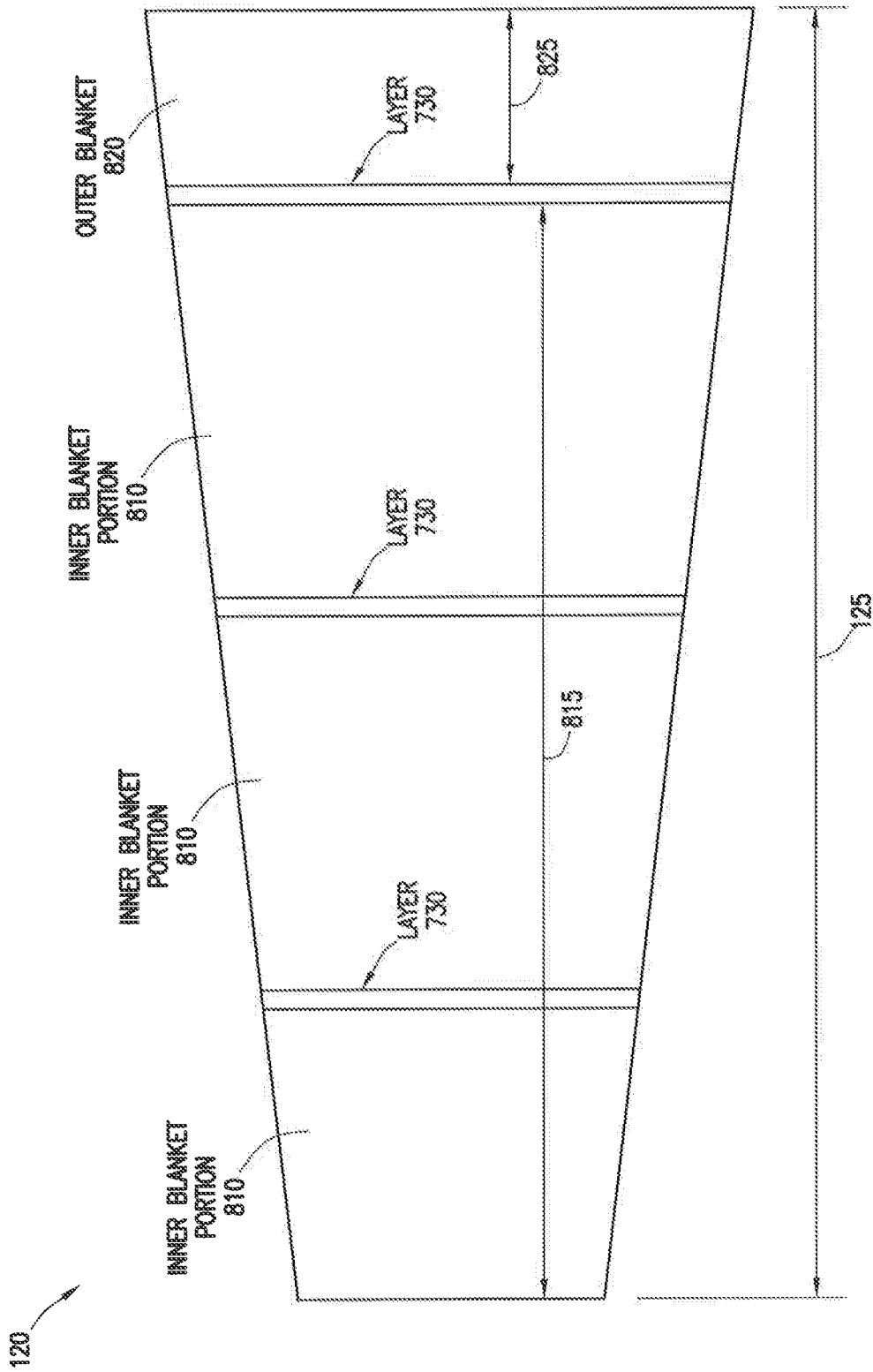

FIG. 8

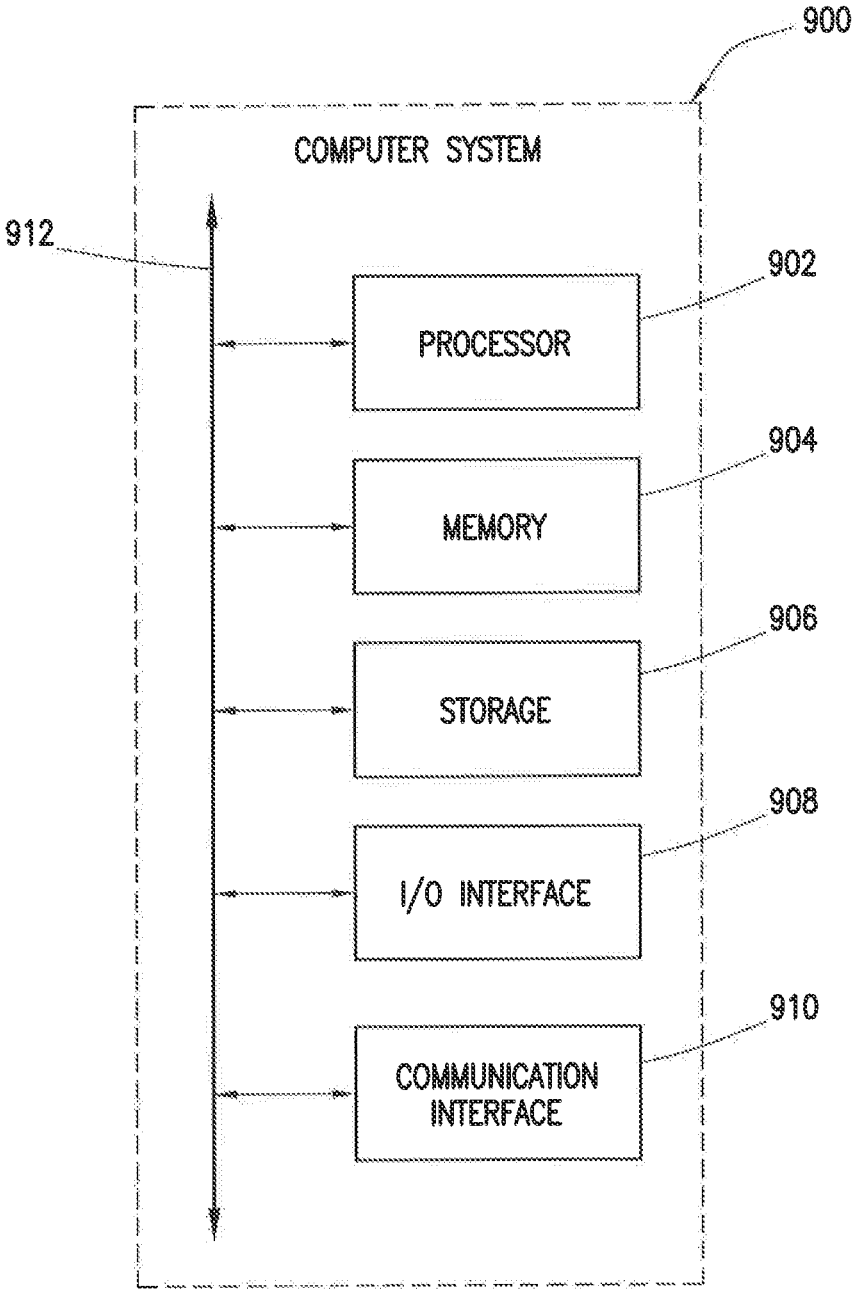

FIG. 9

ENCAPSULATING MAGNETIC FIELDS FOR PLASMA CONFINEMENT

RELATED APPLICATIONS

[0001] This application claims the benefit under 35 U.S.C. § 119(e) of the priority of the following U.S. Provisional Applications filed on Apr. 3, 2013, the entire disclosures of which are hereby incorporated by reference: U.S. Provisional Application No. 61/808136, entitled “MAGNETIC FIELD PLASMA CONFINEMENT FOR COMPACT FUSION POWER”; U.S. Provisional Application No. 61/308122, entitled “MAGNETIC FIELD PLASMA CONFINEMENT FOR COMPACT FUSION POWER”; U.S. Provisional Application No. 61/803131, entitled “ENCAPSULATION AS A METHOD TO ENHANCE MAGNETIC FIELD PLASMA CONFINEMENT”; U.S. Provisional Application No. 61/307932, entitled “SUPPORTS FOR STRUCTURES IMMERSSED IN PLASMA”; U.S. Provisional Application No. 61/808110, entitled “RESONANT HEATING OF PLASMA WITH HELICON ANTENNAS”; U.S. Provisional Application No. 61/808066, entitled “PLASMA HEATING WITH RADIO FREQUENCY WAVES”; U.S. Provisional Application No. 61/308093, entitled “PLASMA HEATING WITH NEUTRAL BEAMS”; U.S. Provisional Application No. 61/308089, entitled “ACTIVE COOLING OF STRUCTURES IMMERSSED IN PLASMA”; U.S. Provisional Application No. 61/808101, entitled “PLASMA HEATING VIA FIELD OSCILLATIONS”; and U.S. Provisional Application No. 61/808154, entitled “DIRECT ENERGY CONVERSION OF FUSION PLASMA ENERGY VIA CYCLED ADIABATIC COMPRESSION AND EXPANSION”.

TECHNICAL FIELD

[0002] This disclosure generally relates to fusion reactors and more specifically to encapsulating magnetic fields for plasma confinement.

BACKGROUND.

[0003] Fusion power is power that is generated by a nuclear fusion process in which two or more atomic nuclei collide at very high speed and join to form a new type of atomic nucleus. A fusion reactor is a device that produces fusion power by confining and controlling plasma. Typical fusion reactors are large, complex, and cannot be mounted on a vehicle

SUMMARY OF PARTICULAR EMBODIMENTS

[0004] According to one embodiment, a fusion reactor includes an enclosure, an open-field magnetic system comprising one or more internal magnetic coils suspended within the enclosure, and one or more encapsulating magnetic coils coaxial with the one or more internal magnetic coils of the open-field magnetic system. The one or more encapsulating magnetic coils form a magnetosphere around the open-field magnetic system. The open-field magnetic system and the one or more encapsulating magnetic coils, when supplied with electrical currents, form magnetic fields for confining plasma within the enclosure

[0005] Technical advantages of certain embodiments may include providing a compact fusion reactor that is less complex and less expensive to build than typical fusion reactors. Some embodiments may provide a fusion reactor

that is compact enough to be mounted on or in a vehicle such as a truck, aircraft, ship, train, spacecraft, or submarine. Some embodiments may provide a fusion reactor that may be utilized in desalination plants or electrical power plants. Other technical advantages will be readily apparent to one skilled in the art from the following figures, descriptions, and claims. Moreover, while specific advantages have been enumerated above, various embodiments may include all, some, or none of the enumerated advantages.

BRIEF DESCRIPTION OF THE DRAWINGS

[0006] FIG. 1 illustrates example applications for fusion reactors, according to certain embodiments.

[0007] FIG. 2 illustrates an example aircraft system utilizing fusion reactors, according to certain embodiments.

[0008] FIGS. 3A and 3B illustrate an example fusion reactor, according to certain embodiments.

[0009] FIGS. 4A-4E illustrate simplified views of the coils of various embodiments of the fusion reactor of FIGS. 3A and 3B, and example systems for energizing the coils, according to certain embodiments.

[0010] FIG. 5 illustrates plasma within the fusion reactor of FIGS. 3A and 3B, according to certain embodiments.

[0011] FIG. 6 illustrates magnetic fields of the fusion reactor of FIGS. 3A and 3B, according to certain embodiments.

[0012] FIG. 7 illustrates an internal coil of the fusion reactor of FIGS. 3A and 3B, according to certain embodiments.

[0013] FIG. 8 illustrates a cut-away view of the enclosure of the fusion reactor of FIGS. 3A and 3B, according to certain embodiments.

[0014] FIG. 9 illustrates an example computer system, according to certain embodiments.

DESCRIPTION OF EXAMPLE EMBODIMENTS

[0015] Fusion reactors generate power by confining and controlling plasma that is used in a nuclear fusion process. Magnetic fields are one of the main methods of confining plasma for the purposes of harnessing nuclear fusion energy. Open field line versions of confining plasma may suffer from particle streaming losses. Some reactors may utilize recirculation to return exiting particles along the field lines by containing the expansive field lines in a much larger device than would be otherwise used. However, these fields become weaker farther away from the device and thus become susceptible to plasma detachment and instability. Additionally, typical fusion reactors are extremely large and complex devices. Because of their prohibitively large plant sizes, it is not feasible to mount typical fusion reactors on vehicles. As a result, the usefulness of typical fusion reactors is limited.

[0016] The teachings of the disclosure recognize that it is desirable to provide a compact fusion reactor that is small enough to mount on vehicles such as trucks, trains, airplanes, ships, submarines, and the like. For example, it is desirable to provide truck-mounted compact fusion reactors that may provide a decentralized power system. As another example, it is desirable to provide a compact fusion reactor for an aircraft that greatly expands the range and operating time of the aircraft. The following describes an encapsulated fusion reactor for providing these and other desired benefits associated with compact fusion reactors. The encapsulation fields of the disclosed devices allow recirculating field lines

to be compressed and contained. The disclosed embodiments contain the fields within a much smaller volume, completely containing the plasma within a magnetosphere much like the magnetosphere surrounding the Earth. The encapsulated fields of the disclosed embodiments are higher strength and less susceptible to instability as well as more compact—a great improvement over typical systems.

[0017] FIG. 1 illustrates applications of a fusion reactor 110, according to certain embodiments. As one example, one or more embodiments of fusion reactor 110 are utilized by aircraft 101 to supply heat to one or more engines (e.g., turbines) of aircraft 101. A specific example of utilizing one or more fusion reactors 110 in an aircraft is discussed in more detail below in reference to FIG. 2. In another example, one or more embodiments of fusion reactor 110 are utilized by ship 102 to supply electricity and propulsion power. While an aircraft carrier is illustrated for ship 102 in FIG. 1, any type of ship (e.g., a cargo ship, a cruise ship, etc.) may utilize one or more embodiments of fusion reactor 110. As another example, one or more embodiments of fusion reactor 110 may be mounted to a flat-bed truck 103 in order to provide decentralized power or for supplying power to remote areas in need of electricity. As another example, one or more embodiments of fusion reactor 110 may be utilized by an electrical power plant 104 in order to provide electricity to a power grid. While specific applications for fusion reactor 110 are illustrated in FIG. 1, the disclosure is not limited to the illustrated applications. For example, fusion reactor 110 may be utilized in other applications such as trains, desalination plants, spacecraft, submarines, and the like.

[0018] In general, fusion reactor 110 is a device that generates power by confining and controlling plasma that is used in a nuclear fusion process. Fusion reactor 110 generates a large amount of heat from the nuclear fusion process that may be converted into various forms of power. For example, the heat generated by fusion reactor 110 may be utilized to produce steam for driving a turbine and an electrical generator, thereby producing electricity. As another example, as discussed further below in reference to FIG. 2, the heat generated by fusion reactor 110 may be utilized directly by a turbine of a turbofan or fanjet engine of an aircraft instead of a combustor.

[0019] Fusion reactor 110 may be scaled to have any desired output for any desired application. For example, one embodiment of fusion reactor 110 may be approximately 10 m×7 m and may have a gross heat output of approximately 100 MW. In other embodiments, fusion reactor 110 may be larger or smaller depending on the application and may have a greater or smaller heat output. For example, fusion reactor 110 may be scaled in size in order to have a gross heat output of over 200 MW.

[0020] FIG. 2 illustrates an example aircraft system 200 that utilizes one or more fusion reactors 110, according to certain embodiments. Aircraft system 200 includes one or more fusion reactors 110, a fuel processor 210, one or more auxiliary power units (APUs) 220, and one or more turbofans 230. Fusion reactors 110 supply hot coolant 240 to turbofans 230 (e.g., either directly or via fuel processor 210) using one or more heat transfer lines. In some embodiments, hot coolant 240 is FLiBe (i.e., a mixture of lithium fluoride (LiF) and beryllium fluoride (BeF₂)) or LiPb. In some embodiments, hot coolant 240 is additionally supplied to APUs 220. Once used by turbofans 240, return coolant 250

is fed back to fusion reactors 110 to be heated and used again. In some embodiments, return coolant 250 is fed directly to fusion reactors 110. In some embodiments, return coolant 250 may additionally be supplied to fusion reactors 110 from APUs 220.

[0021] In general, aircraft system 200 utilizes one or more fusion reactors 110 in order to provide heat via hot coolant 240 to turbofans 230. Typically, a turbofan utilizes a combustor that burns jet fuel in order to heat intake air, thereby producing thrust. In aircraft system 200, however, the combustors of turbofans 230 have been replaced by heat exchangers that utilize hot coolant 240 provided by one or more fusion reactors 110 in order to heat the intake air. This may provide numerous advantages over typical turbofans. For example, by allowing turbofans 230 to operate without combustors that burn jet fuel, the range of aircraft 101 may be greatly extended. In addition, by greatly reducing or eliminating the need for jet fuel, the operating cost of aircraft 101 may be significantly reduced.

[0022] FIGS. 3A and 3B illustrate a fusion reactor 110 that may be utilized in the example applications of FIG. 1, according to certain embodiments. In general, fusion reactor 110 utilizes any open-field magnetic system in order to control plasma 310 within enclosure 120. In some embodiments, fusion reactor 110 is an encapsulated linear ring cusp fusion reactor in which encapsulating magnetic coils 150 are used to prevent plasma that is generated using internal cusp magnetic coils from expanding. In some embodiments, fusion reactor 110 includes an enclosure 120 with a center line 115 running down the center of enclosure 120 as shown. In some embodiments, enclosure 120 includes a vacuum chamber and has a cross-section as discussed below in reference to FIG. 7. Fusion reactor 110 includes internal coils 140 (e.g., internal coils 140a and 140, also known as “cusp” coils), encapsulating coils 150, and mirror coils 160 (e.g., mirror coils 160a and 160b). Internal coils 140 are suspended within enclosure 120 by any appropriate means and are centered on center line 115. Encapsulating coils 150 are also centered on center line 115 and may be either internal or external to enclosure 120. For example, encapsulating coils 150 may be suspended within enclosure 120 in some embodiments. In other embodiments, encapsulating coils 150 may be external to enclosure 120 as illustrated in FIGS. 3A and 3B.

[0023] In general, fusion reactor 110 provides power by controlling and confining plasma 310 within enclosure 120 for a nuclear fusion process. Internal coils 140, encapsulating coils 150, and mirror coils 160 are energized to form magnetic fields which confine plasma 310 into a shape such as the shape shown in FIGS. 3B and 5. Certain gases, such as deuterium and tritium gases, may then be reacted to make energetic particles which heat plasma 310 and the walls of enclosure 120. The generated heat may then be used, for example, to power vehicles. For example, a liquid metal coolant such as FLiBe or LiPb may carry heat from the walls of fusion reactor 110 out to engines of an aircraft. In some embodiments, combustors in gas turbine engines may be replaced with heat exchangers that utilize the generated heat from fusion reactor 110. In some embodiments, electrical power may also be extracted from fusion reactor 110 via magnetohydrodynamic (MHD) processes.

[0024] In embodiments of fusion reactor 110, one or more encapsulating coils 150 provide encapsulation fields that allow recirculating field lines of an open-field magnetic

system within fusion reactor **110** to be compressed and contained. This configuration of encapsulating coils **150** that encapsulate the magnetic fields of the open-field magnetic system within fusion reactor **110** provides a system that contains all the fields within a much smaller volume, completely containing the plasma within a magnetosphere much like the one surrounding the Earth. The encapsulated fields are higher strength and less susceptible to instability as well as more compact—a substantial benefit for compact reactor concepts.

[0025] The general technique of providing one or more encapsulating coils **150** that surround an open-field magnetic system within fusion reactor **110** may be applied to any recirculating open field line device. For example, the open-field magnetic system within fusion reactor **110** may be any linear ring cusp device, a Polywell device, any spindle cusp device, any mirror device, any of the linear-ring cusp devices described herein, or any other magnetic system having open magnetic field lines.

[0026] The general technique of providing one or more encapsulating coils **150** that surround an open-field magnetic system within fusion reactor **110** allows recirculating plasma flow to follow much stronger magnetic field lines. This eliminates the chances for plasma detachment and instabilities. Additionally, encapsulation greatly reduces the size of recirculating field line devices. This may permit compact fusion reactors that may be mounted on any vehicle.

[0027] Encapsulation is generally the process of adding additional external fields (e.g., by using one or more encapsulating coils **150**) to an open field line geometry (i.e., an open-field magnetic system within fusion reactor **110**). The magnetic fields of the one or more encapsulating coils **150** close the original magnetic lines formed by the open-field magnetic system inside a magnetosphere. Closing the magnetic lines can reduce the extent of open field lines and reduce losses via recirculation. All types of dipoles, mirrors, and cusp devices can be encapsulated.

[0028] As discussed above, encapsulating coils **150** may be utilized with any open-field magnetic system to confine plasma for the purposes of harnessing nuclear fusion energy. The following figures illustrate various embodiments of fusion reactor **110** that utilize different open-field magnetic systems to confine plasma **310**. For example, FIG. 3A below illustrates an embodiment of fusion reactor **110** that utilizes encapsulating coils **150** in conjunction with an open-field magnetic system that includes a central linear ring cusp (i.e., center coil **130**), two spindle cusps (i.e., internal coils **140**) that are located axially on either side of the central linear ring cusp, and two mirror coils located axially at the ends (i.e., mirror coils **160**). While particular embodiments of an open-field magnetic system within fusion reactor **110** are illustrated, it should be understood that encapsulating coils **150** may be utilized with any appropriate open-field magnetic system.

[0029] In some embodiments, fusion reactor **110** is an encapsulated linear ring cusp fusion device. The main plasma confinement is accomplished in some embodiments by a central linear ring cusp (e.g., center coil **130**) with two spindle cusps located axially on either side (e.g., internal coils **140**). These confinement regions are then encapsulated (e.g., with encapsulating coils **150**) within a coaxial mirror field provided by mirror coils **160**,

[0030] The magnetic fields of fusion reactor **110** are provided by coaxially located magnetic field coils of varying

sizes and currents. The ring cusp losses of the central region are mitigated by recirculation into the spindle cusps. This recirculating flow is made stable and compact by the encapsulating fields provided by encapsulating coils **150**. The outward diffusion losses and axial losses from the main confinement zones are mitigated by the strong mirror fields of the encapsulating field provided by encapsulating coils **150**. To function as a fusion energy producing device, heat is added to the confined plasma **310**, causing it to undergo fusion reactions and produce heat. This heat can then be harvested to produce useful heat, work, and/or electrical power.

[0031] In some embodiments, additional coils may be utilized to alter the shape of the confinement zones for the purposes of creating confinement zones more suitable for specific purposes. For example, the central confinement well can be expanded into a more spherical shape, increasing its volume and suitability for non-thermal fusion schemes. Another example is the stretching of the central region into a more elongated cigar shape, perhaps for easier integration into aerospace vehicles or for easier power conversion or surface wall effects such as breeding. In certain embodiments, additional central cells may be utilized to expand the fusing volume without increasing losses as the whole stack would still be capped by two spindle cusps on the axis. This serves as a way to modularize the system and tailor the output of a given installation to the power needs.

[0032] Fusion reactor **110** is an improvement over existing systems in part because global MHD stability can be preserved and the losses through successive confinement zones are more isolated due to the scattering of particles moving along the null lines. This feature means that particles moving along the center line are not likely to pass immediately out of the system, but will take many scattering events to leave the system. This increases their lifetime in the device, increasing the ability of the reactor to produce useful fusion power.

[0033] Fusion reactor **110** has novel magnetic field configurations that exhibit global MED stability, has a minimum of particle losses via open field lines, uses all of the available magnetic field energy, and has a greatly simplified engineering design. The efficient use of magnetic fields means the disclosed embodiments may be an order of magnitude smaller than typical systems, which greatly reduces capital costs for power plants. In addition, the reduced costs allow the concept to be developed faster as each design cycle may be completed much quicker than typical system. In general, the disclosed embodiments have a simpler, more stable design with far less physics risk than existing systems.

[0034] Enclosure **120** is any appropriate chamber or device for containing a fusion reaction. In some embodiments, enclosure **120** is a vacuum chamber that is generally cylindrical in shape. In other embodiments, enclosure **120** may be a shape other than cylindrical. In some embodiments, enclosure **120** has a centerline **115** running down a center axis of enclosure **120** as illustrated. In some embodiments, enclosure **120** has a first end **320** and a second end **330** that is opposite from first end **320**. In some embodiments, enclosure **120** has a midpoint **340** that is substantially equidistant between first end **320** and second end **330**. A cross-section of a particular embodiment of enclosure **120** is discussed below in reference to FIG. 8.

[0035] Some embodiments of fusion reactor **110** may include a center coil **130**. Center coil **130** is generally

located proximate to midpoint **340** of enclosure **120**. In some embodiments, center coil **130** is centered on center line **115** and is coaxial with internal coils **140**. Center coil **130** may be either internal or external to enclosure **120**, may be located at any appropriate axial position with respect to midpoint **340**, may have any appropriate radius, may carry any appropriate current, and may have any appropriate amperturns.

[0036] Internal coils **140** are any appropriate magnetic coils that are suspended or otherwise positioned within enclosure **120**. In some embodiments, internal coils **140** are superconducting magnetic coils. In some embodiments, internal coils **140** are toroidal in shape as shown in FIG. 3B. In some embodiments, internal coils **140** are centered on centerline **115**. In some embodiments, internal coils **140** include two coils: a first internal coil **140a** that is located between midpoint **340** and first end **320** of enclosure **120**, and a second internal coil **140b** that is located between midpoint **340** and second end **330** of enclosure **120**. Internal coils **140** may be located at any appropriate axial position with respect to midpoint **340**, may have any appropriate radius, may carry any appropriate current, and may have any appropriate amperturns. A particular embodiment of an internal coil **140** is discussed in more detail below in reference to FIG. 7.

[0037] Encapsulating coils **150** are any appropriate magnetic coils and generally have larger diameters than internal coils **140**. In some embodiments, encapsulating coils **150** are centered on centerline **115** and are coaxial with internal coils **140**. In general, encapsulating coils **150** encapsulate internal coils **140** and operate to close the original magnetic lines of internal coils **140** inside a magnetosphere. Closing these lines may reduce the extent of open field lines and reduce losses via recirculation. Encapsulating coils **150** also preserve the MHD stability of fusion reactor **110** by maintaining a magnetic wall that prevents plasma **310** from expanding. Encapsulating coils **150** have any appropriate cross-section, such as square or round. In some embodiments, encapsulating coils **150** are suspended within enclosure **120**. In other embodiments, encapsulating coils **150** may be external to enclosure **120** as illustrated in FIGS. 3A and 3B. Encapsulating coils **150** may be located at any appropriate axial position with respect to midpoint **340**, may have any appropriate radius, may carry any appropriate current, and may have any appropriate amperturns.

[0038] Fusion reactor **110** may include any number and arrangement of encapsulating coils **150**. In some embodiments, encapsulating coils **150** include at least one encapsulating coil **150** positioned on each side of midpoint **340** of enclosure **120**. For example, fusion reactor **110** may include two encapsulating coils **150**: a first encapsulating coil **150** located between midpoint **340** and first end **320** of enclosure **120**, and a second encapsulating coil **150** located between midpoint **340** and second end **330** of enclosure **120**. In some embodiments, fusion reactor **110** includes a total of two, four, six, eight, or any other even number of encapsulating coils **150**. In certain embodiments, fusion reactor **110** includes a first set of two encapsulating coils **150** located between internal coil **140a** and first end **320** of enclosure **120**, and a second set of two encapsulating coils **150** located between internal coil **140b** and second end **330** of enclosure **120**. While particular numbers and arrangements of encapsulating coils **150** have been disclosed, any appropriate

number and arrangement of encapsulating coils **150** may be utilized by fusion reactor **110**.

[0039] Mirror coils **160** are magnetic coils that are generally located close to the ends of enclosure **120** (i.e., first end **320** and second end **330**). In some embodiments, mirror coils **160** are centered on center line **115** and are coaxial with internal coils **140**. In general, mirror coils **160** serve to decrease the axial cusp losses and make all the recirculating field lines satisfy an average minimum- β , a condition that is not satisfied by other existing recirculating schemes. In some embodiments, mirror coils **160** include two mirror coils **160**: a first mirror coil **160a** located proximate to first end **320** of enclosure **120**, and a second mirror coil **160b** located proximate to second end **330** of enclosure **120**. Mirror coils **160** may be either internal or external to enclosure **120**, may be located at any appropriate axial position with respect to midpoint **340**, may have any appropriate radius, may carry any appropriate current, and may have any appropriate amperturns.

[0040] In some embodiments, coils **130**, **140**, **150**, and **160** are designed or chosen according to certain constraints. For example, coils **130**, **140**, **150**, and **160** may be designed according to constraints including: high required currents (maximum in some embodiments of approx. 10 MegaAmp-turns); steady-state continuous operation; vacuum design (protected from plasma impingement), toroidal shape, limit outgassing; materials compatible with **150C** bakeout; thermal build-up; and cooling between shots.

[0041] Fusion reactor **110** may include one or more heat injectors **170**. Heat injectors **170** are generally operable to allow any appropriate heat to be added to fusion reactor **110** in order to heat plasma **310**. In some embodiments, for example, heat injectors **170** may be utilized to add neutral beams in order to heat plasma **310** within fusion reactor **110**.

[0042] In operation, fusion reactor **110** generates fusion power by controlling the shape of plasma **310** for a nuclear fusion process using at least internal coils **140**, encapsulating coils **150**, and mirror coils **160**. Internal coils **140** and encapsulating coils **150** are energized to form magnetic fields which confine plasma **310** into a shape such as the shape shown in FIGS. 3B and 5. Gases such as deuterium and tritium may then be reacted to make energetic particles which heat plasma **310** and the walls of enclosure **120**. The generated heat may then be used for power. For example, a liquid metal coolant may carry heat from the walls of the reactor out to engines of an aircraft. In some embodiments, electrical power may also be extracted from fusion reactor **110** via MHD.

[0043] In order to expand the volume of plasma **310** and create a more favorable minimum- β geometry, the number of internal coils can be increased to make a cusp. In some embodiments of fusion reactor **110**, the sum of internal coils **140**, center coil **130**, and mirror coils **160** is an odd number in order to obtain the encapsulation by the outer 'solenoid' field (i.e., the magnetic field provided by encapsulating coils **150**). This avoids making a ring cusp field and therefore ruining the encapsulating separatrix. Two internal coils **140** and center coil **130** with alternating polarizations give a magnetic well with minimum- β characteristics within the cusp and a quasi-spherical core plasma volume. The addition of two axial 'mirror' coils (i.e., mirror coils **160**) serves to decrease the axial cusp losses and more importantly makes the recirculating field lines satisfy average minimum- β , a condition not satisfied by other existing recirculating

schemes. In some embodiments, additional pairs of internal coils **140** could be added to create more plasma volume in the well. However, such additions may increase the cost and complexity of fusion reactor **110** and may require additional supports for coils internal to plasma **310**.

[0044] In the illustrated embodiments of fusion reactor **110**, only internal coils **140** are within plasma **310**. In some embodiments, internal coils **140** are suspending within enclosure **120** by one or more supports, such as support **750** illustrated in FIG. 7. While the supports sit outside the central core plasma well, they may still experience high plasma fluxes. Alternatively, internal coils **140** of some embodiments may be amenable to levitation, which would remove the risk and complexity of having support structures within plasma **310**.

[0045] FIG. 4A illustrates a simplified view of the coils of one embodiment of fusion reactor **110** and example systems for energizing the coils. In this embodiment, the field geometry is sized to be the minimum size necessary to achieve adequate ion magnetization with fields that can be produced by simple magnet technology. Adequate ion magnetization was considered to be ~5 ion gyro radii at design average ion energy with respect to the width of the recirculation zone. At the design energy of 100 eV plasma temperature there are 13 ion diffusion jumps and at full 20 KeV plasma energy there are 6.5 ion jumps. This is the lowest to maintain a reasonable magnetic field of 2.2 T in the cusps and keep a modest device size.

[0046] As illustrated in FIG. 4A, certain embodiments of fusion reactor **110** include two mirror coils **160**: a first mirror coil **160a** located proximate to first end **320** of the enclosure and a second magnetic coil **160b** located proximate to second end **330** of enclosure **120**. Certain embodiments of fusion reactor **110** also include a center coil **130** that is located proximate to midpoint **340** of enclosure **120**. Certain embodiments of fusion reactor **110** also include two internal coils **140**: a first internal coil **140a** located between center coil **130** and first end **320** of enclosure **120**, and a second internal coil **140b** located between center coil **130** and second end **330** of enclosure **120**. In addition, certain embodiments of fusion reactor **110** may include two or more encapsulating coils **150**. For example, fusion reactor **110** may include a first set of two encapsulating coils **150** located between first internal coil **140a** and first end **320** of enclosure **120**, and a second set of two encapsulating coils **150** located between second internal coil **140b** and second end **330** of enclosure **120**. In some embodiments, fusion reactor **110** may include any even number of encapsulating coils **150**. In some embodiments, encapsulating coils **150** may be located at any appropriate position along center line **115** other than what is illustrated in FIG. 4A. In general, encapsulating coils **150**, as well as internal coils **140** and mirror coils **160**, may be located at any appropriate position along center line **115** in order to maintain magnetic fields in the correct shape to achieve the desired shape of plasma **310**.

[0047] In some embodiments, electrical currents are supplied to coils **130**, **140**, **150**, and **160** as illustrated in FIGS. 4A-4E. In these figures, each coil has been split along center line **115** and is represented by a rectangle with either an "X" or an "O" at each end. An "X" represents electrical current that is flowing into the plane of the paper, and an "O" represents electrical current that is flowing out the plane of the paper. Using this nomenclature, FIGS. 4A-4E illustrate how in these embodiments of fusion reactor **110**, electrical

currents flow in the same direction through encapsulating coils **150**, center coil **130**, and mirror coils **160** (i.e., into the plane of the paper at the top of the coils), but flow in the opposite direction through internal coils **140** (i.e., into the plane of the paper at the bottom of the coils).

[0048] In some embodiments, the field geometry of fusion reactor **110** may be sensitive to the relative currents in the coils, but the problem can be adequately decoupled to allow for control. First, the currents to opposing pairs of coils can be driven in series to guarantee that no asymmetries exist in the axial direction. The field in some embodiments is most sensitive to the center three coils (e.g., internal coils **140** and center coil **130**). With the currents of internal coil **140** fixed, the current in center coil **130** can be adjusted to tweak the shape of the central magnetic well. This region can be altered into an axial-oriented 'bar-bell' shape by increasing the current on center coil **130** as the increase in flux 'squeezes' the sphere into the axial shape. Alternatively, the current on center coil **130** can be reduced, resulting in a ring-shaped magnetic well at midpoint **340**. The radius of center coil **130** also sets how close the ring cusp null-line comes to internal coils **140** and may be chosen in order to have this null line close to the middle of the gap between center coil **130** and internal coils **140** to improve confinement.

[0049] The radius of internal coils **140** serves to set the balance of the relative field strength between the point cusps and the ring cusps for the central well. The baseline sizes may be chosen such that these field values are roughly equal. While it would be favorable to reduce the ring cusp losses by increasing the relative flux in this area, a balanced approach may be more desirable.

[0050] In some embodiments, the magnetic field is not as sensitive to mirror coils **160** and encapsulating coils **150**, but their dimensions should be chosen to achieve the desired shape of plasma **310**. In some embodiments, mirror coils **160** may be chosen to be as strong as possible without requiring more complex magnets, and the radius of mirror coils **160** may be chosen to maintain good diagnostic access to the device center. Some embodiments may benefit from shrinking mirror coils **160**, thereby achieving higher mirror ratios for less current but at the price of reduced axial diagnostic access.

[0051] In general, encapsulating coils **150** have weaker magnetic fields than the other coils within fusion reactor **110**. Thus, the positioning of encapsulating coils **150** is less critical than the other coils. In some embodiments, the positions of encapsulating coils **150** are defined such that uninterrupted access to the device core is maintained for diagnostics. In some embodiments, an even number of encapsulating coils **150** may be chosen to accommodate supports for internal coils **140**. The diameters of encapsulating coils **150** are generally greater than those of internal coils **140**, and may be all equal for ease of manufacture and common mounting on or in a cylindrical enclosure **120**. In some embodiments, encapsulating coils **150** may be moved inward to the plasma boundary, but this may impact manufacturability and heat transfer characteristics of fusion reactor **110**.

[0052] In some embodiments, fusion reactor **110** includes various systems for energizing center coil **130**, internal coils **140**, encapsulating coils **150**, and mirror coils **160**. For example, a center coil system **410**, an encapsulating coil system **420**, a mirror coil system **430**, and an internal coil

system 440 may be utilized in some embodiments. Coil systems 410-440 and coils 130-160 may be coupled as illustrated in FIG. 4A. Coil systems 410-440 may be any appropriate systems for driving any appropriate amount of electrical currents through coils 130-160. Center coil system 410 may be utilized to drive center coil 130, encapsulating coil system 420 may be utilized to drive encapsulating coils 150, mirror coil system 430 may be utilized to drive mirror coils 160, and internal coil system 440 may be utilized to drive internal coils 140. In other embodiments, more or fewer coil systems may be utilized than those illustrated in FIG. 4A. In general, coil systems 410-440 may include any appropriate power sources such as battery banks.

[0053] FIG. 4B illustrates coils 130-160 of another embodiment of fusion reactor 110. In this embodiment, fusion reactor 110 includes a center coil 130, two internal coils 140, and two mirror coils 160. In addition, this embodiment of fusion reactor 110 includes six encapsulating coils 150. While specific locations of coils 130-160 are illustrated, coils 140-160 may be located in any appropriate positions along center line 115 in order to maintain a desired shape of plasma 310 within enclosure 120.

[0054] FIG. 4C illustrates coils 130-160 of another embodiment of fusion reactor 110. In this embodiment, fusion reactor 110 includes two center coils 130, three internal coils 140, and two mirror coils 160. In addition, this embodiment of fusion reactor 110 includes six encapsulating coils 150. While specific locations of coils 130-160 are illustrated, coils 140-160 may be located in any appropriate positions along center line 115 in order to maintain a desired shape of plasma 310 within enclosure 120.

[0055] FIG. 4D illustrates coils 130-160 of another embodiment of fusion reactor 110. In this embodiment, fusion reactor 110 includes two center coils 130, four internal coils 140, and four mirror coils 160. In addition, this embodiment of fusion reactor 110 includes eight encapsulating coils 150. While specific locations of coils 130-160 are illustrated, coils 140-160 may be located in any appropriate positions along center line 115 in order to maintain a desired shape of plasma 310 within enclosure 120.

[0056] FIG. 4E illustrates coils 130-160 of another embodiment of fusion reactor 110. In this embodiment, fusion reactor 110 includes a center coil 130, four internal coils 140, and four mirror coils 160. In addition, this embodiment of fusion reactor 110 includes four encapsulating coils 150. While specific locations of coils 130-160 are illustrated, coils 140-160 may be located in any appropriate positions along center line 115 in order to maintain a desired shape of plasma 310 within enclosure 120.

[0057] As illustrated in the various embodiments of FIGS. 4A-4E above, embodiments of fusion reactor 110 may have any appropriate number, combination, and spacing of internal coils 140, encapsulating coils 150, and mirror coils 160. In general, fusion reactor 110 has a center coil 130, two or more internal coils 140 (e.g., two, four, six, etc.), two or more mirror coils 160 (e.g., two, four, six, etc.), and one or more encapsulating coils 150 that provide a magnetic field that encapsulates internal coils 140. This disclosure anticipates any number, combination, and spacing of internal coils 140, encapsulating coils 150, and mirror coils 160 and is not limited to the illustrated embodiments.

[0058] FIG. 5 illustrates plasma 310 within enclosure 120 that is shaped and confined by center coil 130, internal coils 140, encapsulating coils 150, and mirror coils 160. As

illustrated, an external mirror field is provided by mirror coils 160. The ring cusp flow is contained inside the mirror. A trapped magnetized sheath 510 that is provided by encapsulating coils 150 prevents detachment of plasma 310. Trapped magnetized sheath 510 is a magnetic wall that causes plasma 310 to recirculate and prevents plasma 310 from expanding outward. The recirculating flow is thus forced to stay in a stronger magnetic field. This provides complete stability in a compact and efficient cylindrical geometry. Furthermore, the only losses from plasma exiting fusion reactor 110 are at two small point cusps at the ends of fusion reactor 110 along center line 115. This is an improvement over typical designs in which plasma detaches and exits at other locations.

[0059] The losses of certain embodiments of fusion reactor 110 are also illustrated in FIG. 5. As mentioned above, the only losses from plasma exiting fusion reactor 110 are at two small point cusps at the ends of fusion reactor 110 along center line 115. Other losses may include diffusion losses due to internal coils 140 and axial cusp losses. In addition, in embodiments in which internal coils 140 are suspended within enclosure 120 with one or more supports (e.g., "stalks"), fusion reactor 110 may include ring cusp losses due to the supports.

[0060] In some embodiments, internal coils 140 may be designed in such a way as to reduce diffusion losses. For example, certain embodiments of fusion reactor 110 may include internal coils 140 that are configured to conform to the shape of the magnetic field. This may allow plasma 310, which follows the magnetic field lines, to avoid touching internal coils 140, thereby reducing or eliminating losses. An example embodiment of internal coils 140 illustrating a conformal shape is discussed below in reference to FIG. 7.

[0061] FIG. 6 illustrates a magnetic field of certain embodiments of fusion reactor 110. In general, fusion reactor 110 is designed to have a central magnetic well that is desired for high beta operation and to achieve higher plasma densities. As illustrated in FIG. 6, the magnetic field may include three magnetic wells. The central magnetic well can expand with high Beta, and fusion occurs in all three magnetic wells. Another desired feature is the suppression of ring cusp losses. As illustrated in FIG. 6, the ring cusps connect to each other and recirculate. In addition, good MHD stability is desired in all regions. As illustrated in FIG. 6, only two field penetrations are needed and MHD interchange is satisfied everywhere.

[0062] In some embodiments, the magnetic fields can be altered without any relocation of the coils by reducing the currents, creating for example weaker cusps and changing the balance between the ring and point cusps. The polarity of the currents could also be reversed to make a mirror-type field and even an encapsulated mirror. In addition, the physical locations of the coils could be altered.

[0063] FIG. 7 illustrates an example embodiment of an internal coil 140 of fusion reactor 110. In this embodiment, internal coil 140 includes coil windings 710, inner shield 720, layer 730, and outer shield 740. In some embodiments, internal coil 140 may be suspended within enclosure 120 with one or more supports 750. Coil windings 710 may have a width 715 and may be covered in whole or in part by inner shield 720. Inner shield 720 may have a thickness 725 and may be covered in whole or in part by layer 730. Layer 730 may have a thickness 735 and may be covered in whole or in part by outer shield 740. Outer shield may have a

thickness 745 and may have a shape that is conformal to the magnetic field within enclosure 120. In some embodiments, internal coil 140 may have an overall diameter of approximately 1.04 m.

[0064] Coil windings 710 form a superconducting coil and carry an electric current that is typically in an opposite direction from encapsulating coils 150, center coil 130, and mirror coils 160. In some embodiments, width 715 of coils winding is approximately 20 cm. Coil windings 710 may be surrounded by inner shield 720. Inner shield 720 provides structural support, reduces residual neutron flux, and shields against gamma rays due to impurities. Inner shield 720 may be made of Tungsten or any other material that is capable of stopping neutrons and gamma rays. In some embodiments, thickness 725 of inner shield 720 is approximately 11.5 cm.

[0065] In some embodiments, inner shield 720 is surrounded by layer 730. Layer 730 may be made of lithium (e.g., lithium-6) and may have thickness 735 of approximately 5 mm. Layer 730 may be surrounded by outer shield 740. Outer shield 740 may be made of FLiBe and may have thickness 745 of approximately 30 cm. In some embodiments, outer shield may be conformal to magnetic fields within enclosure 120 in order to reduce losses. For example, outer shield 740 may form a toroid.

[0066] FIG. 8 illustrates a cut-away view of enclosure 120 of certain embodiments of fusion reactor 110. In some embodiments, enclosure 120 includes one or more inner blanket portions 810, an outer blanket 820, and one or more layers 730 described above. In the illustrated embodiment, enclosure 120 includes three inner blanket portions 810 that are separated by three layers 730. Other embodiments may have any number or configuration of inner blanket portions 810, layers 730, and outer blanket 820. In some embodiments, enclosure 120 may have a total thickness 125 of approximately 80 cm in many locations. In other embodiments, enclosure 120 may have a total thickness 125 of approximately 1.50 m in many locations. However, thickness 125 may vary over the length of enclosure 120 depending on the shape of the magnetic field within enclosure 120 (i.e., the internal shape of enclosure 120 may conform to the magnetic field as illustrated in FIG. 3b and thus may not be a uniform thickness 125).

[0067] In some embodiments, inner blanket portions 610 have a combined thickness 815 of approximately 70 cm. In other embodiments, inner blanket portions 810 have a combined thickness 815 of approximately 126 cm. In some embodiments, inner blanket portions are made of materials such as Be, FLiBe, and the like.

[0068] Outer blanket 820 is any low activation material that does not tend to become radioactive under irradiation. For example, outer blanket 820 may be iron or steel. In some embodiments, outer blanket 820 may have a thickness 825 of approximately 10 cm.

[0069] FIG. 9 illustrates an example computer system 900. In particular embodiments, one or more computer systems 900 are utilized by fusion reactor 110 for any aspects requiring computerized control. Particular embodiments include one or more portions of one or more computer systems 900. Herein, reference to a computer system may encompass a computing device, and vice versa, where appropriate. Moreover, reference to a computer system may encompass one or more computer systems, where appropriate.

[0070] This disclosure contemplates any suitable number of computer systems 900. This disclosure contemplates computer system 900 taking any suitable physical form. As example and not by way of limitation, computer system 900 may be an embedded computer system, a system-on-chip (SOC), a single-board computer system (SEC) (such as, for example, a computer-on-module (COM) or system-on-module (SOM)), a desktop computer system, a laptop or notebook computer system, an interactive kiosk, a mainframe, a mesh of computer systems, a mobile telephone, a personal digital assistant (PDA), a server, a tablet computer system, or a combination of two or more of these. Where appropriate, computer system 900 may include one or more computer systems 900; be unitary or distributed; span multiple locations; span multiple machines; span multiple data centers; or reside in a cloud, which may include one or more cloud components in one or more networks. Where appropriate, one or more computer systems 900 may perform without substantial spatial or temporal limitation one or more steps of one or more methods described or illustrated herein. As an example and not by way of limitation, one or more computer systems 900 may perform in real time or in batch mode one or more steps of one or more methods described or illustrated herein. One or more computer systems 900 may perform at different times or at different locations one or more steps of one or more methods described or illustrated herein, where appropriate.

[0071] In particular embodiments, computer system 900 includes a processor 902, memory 904, storage 906, an input/output (I/O) interface 908, a communication interface 910, and a bus 912. Although this disclosure describes and illustrates a particular computer system having a particular number of particular components in a particular arrangement, this disclosure contemplates any suitable computer system having any suitable number of any suitable components in any suitable arrangement.

[0072] In particular embodiments, processor 902 includes hardware for executing instructions, such as those making up a computer program. As an example and not by way of limitation, to execute instructions, processor 902 may retrieve (or fetch) the instructions from an internal register, an internal cache, memory 904, or storage 906; decode and execute them; and then write one or more results to an internal register, an internal cache, memory 904, or storage 906. In particular embodiments, processor 902 may include one or more internal caches for data, instructions, or addresses. This disclosure contemplates processor 902 including any suitable number of any suitable internal caches, where appropriate. As an example and not by way of limitation, processor 902 may include one or more instruction caches, one or more data caches, and one or more translation lookaside buffers (TLBs). Instructions in the instruction caches may be copies of instructions in memory 904 or storage 906, and the instruction caches may speed up retrieval of those instructions by processor 902. Data in the data caches may be copies of data in memory 904 or storage 906 for instructions executing at processor 902 to operate on; the results of previous instructions executed at processor 902 for access by subsequent instructions executing at processor 902 or for writing to memory 904 or storage 906; or other suitable data. The data caches may speed up read or write operations by processor 902. The TLBs may speed up virtual-address translation for processor 902. In particular embodiments, processor 902 may include one or more

internal registers for data, instructions, or addresses. This disclosure contemplates processor 902 including any suitable number of any suitable internal registers, where appropriate. Where appropriate, processor 902 may include one or more arithmetic logic units (ALUs); be a multi-core processor; or include one or more processors 902. Although this disclosure describes and illustrates a particular processor, this disclosure contemplates any suitable processor.

[0073] In particular embodiments, memory 904 includes main memory for storing instructions for processor 902 to execute or data for processor 902 to operate on. As an example and not by way of limitation, computer system 900 may load instructions from storage 906 or another source (such as, for example, another computer system 900) to memory 904. Processor 902 may then load the instructions from memory 904 to an internal register or internal cache. To execute the instructions, processor 902 may retrieve the instructions from the internal register or internal cache and decode them. During or after execution of the instructions, processor 902 may write one or more results (which may be intermediate or final results) to the internal register or internal cache. Processor 902 may then write one or more of those results to memory 904. In particular embodiments, processor 902 executes only instructions in one or more internal registers or internal caches or in memory 904 (as opposed to storage 906 or elsewhere) and operates only on data in one or more internal registers or internal caches or in memory 904 (as opposed to storage 906 or elsewhere). One or more memory buses (which may each include an address bus and a data bus) may couple processor 902 to memory 904. Bus 912 may include one or more memory buses, as described below. In particular embodiments, one or more memory management units (MMUs) reside between processor 902 and memory 904 and facilitate accesses to memory 904 requested by processor 902. In particular embodiments, memory 904 includes random access memory (RAM). This RAM may be volatile memory, where appropriate. Where appropriate, this RAM may be dynamic RAM (DRAM) or static RAM (SRAM). Moreover, where appropriate, this RAM may be single-ported or multi-ported RAM. This disclosure contemplates any suitable RAM. Memory 904 may include one or more memories 904, where appropriate. Although this disclosure describes and illustrates particular memory, this disclosure contemplates any suitable memory.

[0074] In particular embodiments, storage 906 includes mass storage for data or instructions. As an example and not by way of limitation, storage 906 may include a hard disk drive (HDD), a floppy disk drive, flash memory, an optical disc, a magneto-optical disc, magnetic tape, or a Universal Serial Bus (USB) drive or a combination of two or more of these. Storage 906 may include removable or non-removable (or fixed) media, where appropriate. Storage 906 may be internal or external to computer system 900, where appropriate. In particular embodiments, storage 906 is non-volatile, solid-state memory. In particular embodiments, storage 906 includes read-only memory (ROM). Where appropriate, this ROM may be mask-programmed ROM, programmable ROM (PROM), erasable PROM (EPROM), electrically erasable PROM (EEPROM), electrically alterable ROM (EAROM), or flash memory or a combination of two or more of these. This disclosure contemplates mass storage 906 taking any suitable physical form. Storage 906 may include one or more storage control units facilitating communication between processor 902 and storage 906,

where appropriate. Where appropriate, storage 906 may include one or more storages 906. Although this disclosure describes and illustrates particular storage, this disclosure contemplates any suitable storage.

[0075] In particular embodiments, I/O interface 908 includes hardware, software, or both, providing one or more interfaces for communication between computer system 900 and one or more I/O devices. Computer system 900 may include one or more of these I/O devices, where appropriate. One or more of these I/O devices may enable communication between a person and computer system 900. As an example and not by way of limitation, an I/O device may include a keyboard, keypad, microphone, monitor, mouse, printer, scanner, speaker, still camera, stylus, tablet, touch screen, trackball, video camera, another suitable I/O device or a combination of two or more of these. An I/O device may include one or more sensors. This disclosure contemplates any suitable I/O devices and any suitable I/O interfaces 908 for them. Where appropriate, I/O interface 908 may include one or more device or software drivers enabling processor 902 to drive one or more of these I/O devices. I/O interface 908 may include one or more I/O interfaces 908, where appropriate. Although this disclosure describes and illustrates a particular I/O interface, this disclosure contemplates any suitable I/O interface.

[0076] In particular embodiments, communication interface 910 includes hardware, software, or both providing one or more interfaces for communication (such as, for example, packet-based communication) between computer system 900 and one or more other computer systems 900 or one or more networks. As an example and not by way of limitation, communication interface 910 may include a network interface controller (NIC) or network adapter for communicating with an Ethernet or other wire-based network or a wireless NIC (WNIC) or wireless adapter for communicating with a wireless network, such as a WI-FI network. This disclosure contemplates any suitable network and any suitable communication interface 910 for it. As an example and not by way of limitation, computer system 900 may communicate with an ad hoc network, a personal area network (PAN), a local area network (LAN), a wide area network (WAN), a metropolitan area network (MAN), or one or more portions of the Internet or a combination of two or more of these. One or more portions of one or more of these networks may be wired or wireless. As an example, computer system 900 may communicate with a wireless PAN (WPAN) (such as, for example, a BLUETOOTH WPAN), a WI-FI network, a WI-MAX network, a cellular telephone network (such as, for example, a Global System for Mobile Communications (GSM) network), or other suitable wireless network or a combination of two or more of these. Computer system 900 may include any suitable communication interface 910 for any of these networks, where appropriate. Communication interface 910 may include one or more communication interfaces 910, where appropriate. Although this disclosure describes and illustrates a particular communication interface, this disclosure contemplates any suitable communication interface.

[0077] In particular embodiments, bus 912 includes hardware, software, or both coupling components of computer system 900 to each other. As an example and not by way of limitation, bus 912 may include an Accelerated Graphics Port (AGP) or other graphics bus, an Enhanced Industry Standard Architecture (EISA) bus, a front-side bus (FSB), a

HYPERTRANSPORT (HT) interconnect, an Industry Standard Architecture (ISA) bus, an INFINIBAND interconnect, a low-pin-count (LPC) bus, a memory bus, a Micro Channel Architecture (MCA) bus, a Peripheral Component Interconnect (PCI) bus, a PCI-Express (PCIe) bus, a serial advanced technology attachment (SATA) bus, a Video Electronics Standards Association local (VLB) bus, or another suitable bus or a combination of two or more of these. Bus 912 may include one or more buses 912, where appropriate. Although this disclosure describes and illustrates a particular bus, this disclosure contemplates any suitable bus or interconnect.

[0078] Herein, a computer-readable non-transitory storage medium or media may include one or more semiconductor-based or other integrated circuits (ICs) (such as, for example, field-programmable gate arrays (FPGAs) or application-specific ICs (ASICs)), hard disk drives (HDDs), hybrid hard drives (HHDs), optical discs, optical disc drives (ODDs), magneto-optical discs, magneto-optical drives, floppy diskettes, floppy disk drives (FDDs), magnetic tapes, solid-state drives (SSDs), RAM-drives, SECURE DIGITAL cards or drives, any other suitable computer-readable non-transitory storage media, or any suitable combination of two or more of these, where appropriate. A computer-readable non-transitory storage medium may be volatile, non-volatile, or a combination of volatile and non-volatile, where appropriate.

[0079] Herein, “or” is inclusive and not exclusive, unless expressly indicated otherwise or indicated otherwise by context. Therefore, herein, “A or B” means “A, B, or both,” unless expressly indicated otherwise or indicated otherwise by context. Moreover, “and” is both joint and several, unless expressly indicated otherwise or indicated otherwise by context. Therefore, herein, “A and B” means “A and B, jointly or severally,” unless expressly indicated otherwise or indicated otherwise by context.

[0080] The scope of this disclosure encompasses all changes, substitutions, variations, alterations, and modifications to the example embodiments described or illustrated herein that a person having ordinary skill in the art would comprehend. The scope of this disclosure is not limited to the example embodiments described or illustrated herein. Moreover, although this disclosure describes and illustrates respective embodiments herein as including particular components, elements, functions, operations, or steps, any of these embodiments may include any combination or permutation of any of the components, elements, functions, operations, or steps described or illustrated anywhere herein that a person having ordinary skill in the art would comprehend. Furthermore, reference in the appended claims to an apparatus or system or a component of an apparatus or system being adapted to, arranged to, capable of, configured to, enabled to, operable to, or operative to perform a particular function encompasses that apparatus, system, component, whether or not it or that particular function is activated, turned on, or unlocked, as long as that apparatus, system, or component is so adapted, arranged, capable, configured, enabled, operable, or operative.

1. A confinement system comprising:
an enclosure;

an open-field magnetic system comprising one or more superconducting internal magnetic coils suspended within the enclosure and co-axial with a center axis of the enclosure, wherein the one or more superconducting internal magnetic coils each have a radius config-

ured to balance the relative field strength between a plurality of point cusps and a plurality of ring cusps;
a plurality of encapsulating magnetic coils co-axial with a center axis of the enclosure, the plurality of encapsulating magnetic coils having a larger diameter than the one or more internal magnetic coils of the open-field magnetic system, the plurality of encapsulating magnetic coils operable to form a magnetosphere around the open-field magnetic system; and

one or more coil systems configured to supply the open-field magnetic system and the plurality of encapsulating magnetic coils with electrical currents to form magnetic fields for confining plasma within a magnetized sheath in the enclosure, wherein the magnetized sheath and plasma confined within the magnetized sheath encircle each of the one or more internal magnetic coils.

2. The confinement system of claim 1, wherein the plurality of encapsulating magnetic coils are operable to maintain a magnetic wall that prevents the plasma from expanding.

3. The confinement system of claim 1, wherein the plurality of encapsulating magnetic coils are located within the enclosure.

4. The confinement system of claim 1, wherein the one or more internal coils of the open-field magnetic system are toroidal in shape.

5. The confinement system of claim 1, wherein the enclosure is substantially cylindrical in shape.

6. (canceled)

7. The confinement system of claim 1, wherein the open-field magnetic system comprises a magnetic mirror system.

8. The confinement system of claim 1, wherein the open-field magnetic system comprises a cusp system, the cusp system comprising magnetic fields forming one or more magnetic field cusps.

9. A confinement system comprising:
an enclosure;

an open-field magnetic system comprising one or more superconducting internal magnetic coils suspended within the enclosure, wherein the one or more superconducting internal magnetic coils each have a radius configured to balance the relative field strength between a plurality of point cusps and a plurality of ring cusps;

one or more encapsulating magnetic coils coaxial with the one or more internal magnetic coils of the open-field magnetic system, the one or more encapsulating magnetic coils operable to form a magnetosphere around the open-field magnetic system; and

one or more coil systems configured to supply wherein the open-field magnetic system and the one or more encapsulating magnetic coils are operable, when supplied with electrical currents to form magnetic fields for confining plasma within a magnetized sheath in the enclosure, wherein the magnetized sheath and plasma confined within the magnetized sheath encircle each of the one or more internal magnetic coils.

10. The confinement system of claim 9, wherein the one or more encapsulating magnetic coils have a larger diameter than the one or more internal magnetic coils of the open-field magnetic system.

11. The confinement system of claim 9, wherein the one or more encapsulating magnetic coils are external to the enclosure.

12. (canceled)

13. The confinement system of claim 9, wherein the open-field magnetic system comprises a magnetic mirror system.

14. The confinement system of claim 9, wherein the open-field magnetic system comprises a cusp system, the cusp system comprising magnetic fields forming one or more magnetic field cusps.

15. A confinement system comprising:

an open-field magnetic system comprising one or more superconducting internal magnetic coils suspended within an enclosure, wherein the one or more superconducting internal magnetic coils each have a radius configured to balance the relative field strength between a plurality of point cusps and a plurality of ring cusps;

one or more encapsulating magnetic coils coaxial with the one or more internal magnetic coils of the open-field magnetic system, the one or more encapsulating magnetic coils operable to form a magnetosphere around the open-field magnetic system; and

one or more coil systems configured to supply the open-field magnetic system and the one or more encapsulating magnetic coils with electrical currents to form magnetic fields for confining plasma within a magnetized sheath in the enclosure, wherein the magnetized sheath and plasma confined within the magnetized sheath encircle each of the one or more internal magnetic coils.

16. The confinement system of claim 15, wherein the one or more encapsulating magnetic coils have a larger diameter than the one or more internal magnetic coils of the open-field magnetic system.

17. The confinement system of claim 15, wherein the one or more encapsulating magnetic coils are external to the enclosure.

18. (canceled)

19. The confinement system of claim 15, wherein the open-field magnetic system comprises a magnetic mirror system.

20. The confinement system of claim 15, wherein the open-field magnetic system comprises a cusp system, the cusp system comprising magnetic fields forming one or more magnetic field cusps.

21. The confinement system of claim 1, further comprising:

a center magnetic coil located proximate to a midpoint of the enclosure; and

two mirror magnetic coils comprising first and second mirror magnetic coils disposed on opposite sides of the center magnetic coil.

22. The confinement system of claim 1, wherein the one or more coil systems comprise:

a center coil system configured to supply first electrical currents flowing in a first direction through a center magnetic coil;

an internal coil system configured to supply second electrical currents flowing in a second direction through each of the one or more internal magnetic coils;

an encapsulating coil system configured to supply third electrical currents flowing in the first direction through each of the plurality of encapsulating magnetic coils; and

a mirror coil system configured to supply fourth electrical currents flowing in the first direction through each of two mirror magnetic coils.

23. The confinement system of claim 1, wherein each of the one or more internal magnetic coils comprise at least a first shielding surrounding the internal magnetic coil and each of the one or more internal magnetic coils is suspended within the enclosure by at least one support.

24. The confinement system of claim 9, further comprising:

a center magnetic coil located proximate to a midpoint of the enclosure; and

two mirror magnetic coils comprising first and second mirror magnetic coils disposed on opposite sides of the center magnetic coil.

25. The confinement system of claim 9, wherein the one or more coil systems comprise:

a center coil system configured to supply first electrical currents flowing in a first direction through a center magnetic coil;

an internal coil system configured to supply second electrical currents flowing in a second direction through each of the one or more internal magnetic coils;

an encapsulating coil system configured to supply third electrical currents flowing in the first direction through each of the one or more of encapsulating magnetic coils; and

a mirror coil system configured to supply fourth electrical currents flowing in the first direction through each of two mirror magnetic coils.

26. The confinement system of claim 9, wherein each of the one or more internal magnetic coils comprise at least a first shielding surrounding the internal magnetic coil and each of the one or more internal magnetic coils is suspended within the enclosure by at least one support.

27. The confinement system of claim 15, further comprising:

a center magnetic coil located proximate to a midpoint of the enclosure; and

two mirror magnetic coils comprising first and second mirror magnetic coils disposed on opposite sides of the center magnetic coil.

28. The confinement system of claim 15, wherein the one or more coil systems comprise:

a center coil system configured to supply first electrical currents flowing in a first direction through a center magnetic coil;

an internal coil system configured to supply second electrical currents flowing in a second direction through each of the one or more internal magnetic coils;

an encapsulating coil system configured to supply third electrical currents flowing in the first direction through each of the one or more of encapsulating magnetic coils; and

a mirror coil system configured to supply fourth electrical currents flowing in the first direction through each of two mirror magnetic coils.

29. The confinement system of claim 15, wherein each of the one or more internal magnetic coils comprise at least a first shielding surrounding the internal magnetic coil and each of the one more internal magnetic coils is suspended within the enclosure by at least one support.

* * * * *